

400-8876-858  
www.chinajack.com



服务号  
Service number



订阅号  
Subscription number

# 杰克零件手册

Jack Spare Parts Catalogue

杰克缝纫机股份有限公司

浙江省台州市椒江区省台东海大道东段 1008 号  
电话：0086-576-88177788 88177789  
传真：0086-576-88177758

**JACK SEWING MACHINE CO.,LTD.**

No.1008 Donghai Road Jiaojiang District ,Taizhou ,Zhejiang, China  
TEL : 0086-576-88177788 88177789  
FAX : 0086-576-88177758

杰克原厂 品质保障  
Jack Original Quality Assurance

「哪怕只好**1%**  
我们愿意多投**100%**  
历经严苛测试、层层质检  
确保缝纫机体验焕然如初」

「Even if the increase is only **1%**,  
we are willing to invest more than **100%** effort,  
after rigorous tests and layers of quality inspection,  
to ensure that the sewing experience as good as initial.」







## 关于杰克 About JACK

杰克缝纫机股份有限公司创建于1995年，是一家专注于工业缝纫机、自动裁床、电机、服装智能生产管理系统的研发、生产和销售的全球化企业，拥有7000多名员工，在上海证券交易所主板上市，股票代码603337。

经过二十多年的经营和发展，公司已成为全球缝制设备行业中产销规模最大的企业，是一家率先集缝前、缝中及软件为一体的服装智能制造成套解决方案服务商。产品销往全球130多个国家，服务于服装、鞋业、箱包、家具、皮革、汽车、航空等多个领域。近年来，公司保持稳健经营，连续9年行业销量遥遥领先。

公司组建了颇具规模的千人研发团队，拥有院士工作站、博士后工作站、重点企业研究院等。引入并坚持IPD流程，形成了一套较为完善的产品开发管理体系，拥有有效

专利1000多项。

公司先后获得制造业单项冠军示范企业、中国工业大奖提名奖、国家技术创新示范企业、国家企业技术中心、国家火炬计划重点高新技术企业、国家知识产权示范企业、中国轻工业品牌50强等国家级荣誉。

公司先后收购了德国奔马、意大利迈卡、意大利威比玛、安徽旭豪公司，通过国内外并购，不断吸收消化国内外先进技术，形成了德国、意大利、北京、杭州、西安、武汉、台州、池州多地协同联动的全球化研发平台，持续推动公司高质量发展。

从中国制造到中国创造，杰克在国际缝制设备行业中脱颖而出，让天下没有难做的服装，让“中国智造”引领世界潮流！

Jack Sewing Machine Co., Ltd was founded in 1995. Jack is a global company which focuses on industrial sewing machine, automatic cutter, power-saving motor, intelligent production management systems R&D, production and marketing. Jack has more than 7000 staff and listed on the main board of the Shanghai Stock Exchange (stock code: 603337).

After more than 20 years of operation and development, Jack has become the largest enterprise in the global sewing equipment industry. It is the only garment intelligent manufacturing complete solution service provider integrating pre-sewing, sewing and software. Products are sold to more than 130 countries around the world, serving the clothing, footwear, luggage, furniture, leather, automotive, aviation and other fields. In recent years, Jack has maintained a stable operation leading in global sales for 9 consecutive years.

Jack has established a large-scale research and development team of thousands of people, which has academician workstation, postdoctoral workstation, key enterprise research institute etc.. Jack introduces and adheres the IPD process and formed a relatively complete product development

management system, with more than 1,000 effective patents. Jack has successively won plenty of national honor, such as the manufacturing single champion model enterprise, China Industrial Award Nomination Award, National Technology Innovation Model Enterprise, National Enterprise Technology Center, National Torch Program key high-tech enterprises, National Intellectual Property Model Enterprise, China's top 50 light industry brands etc.

Jack has acquired German Bullmer, Italian MAICA, Italian VIBEMAC and Anhui TTY company. Through the domestic and foreign mergers and acquisitions to absorb and digest advanced technologies at home and abroad continuously, Jack has formed multi-site collaborative linkage of global R&D platform, such as Germany, Italy, Beijing, Hangzhou, Xi'an, Wuhan, Taizhou, Chizhou.

From "made in China" to "created in China", Jack will stand out in the international sewing equipment industry:

To make it no difficulty to do garments manufacturing  
And let the "intelligent manufacturing in China" led the world trend!



品质源于态度  
百年成就经典

Quality comes from attitude  
A century create the classic

每一个零件的标准都精确到毫厘  
每一个细节的打磨都精准无瑕  
每一道工序都饱含对专业的敬畏

Each standard of spare parts is accurate to the least bit  
Each detail is precise and impeccable  
Each processure is full of great reverence to specialty



杰克质检 Jack quality inspection

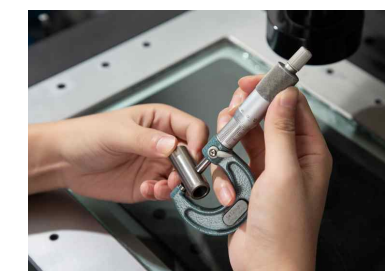

质量把控，层层筛选，客户满意是检验我们的唯一标准！  
Quality control, layers screening, customer satisfaction is our only standard of inspection.

杰克荣誉 Jack honor



中国轻工业缝制机械  
行业十强企业行业排名1  
Rank No.1 in Top 10 of China  
Light Industry in Sewing Machinery



全国售后服务十佳单位  
Top 10 of China After-sale Service



浙江省质量奖  
Zhejiang Quality Award



国家知识产权优势企业  
Competitive Enterprises of  
National Intellectual Property



浙江制造认证证书  
Zhejiang  
Manufacturing Certificate



亚洲设计大奖  
Asian Design Award



中国轻工业百强企业  
Top 100 China  
Light Industry



# 目录 | Directory

## 零件类 | Spare Parts

梭芯/梭壳   Bobbin / Bobbin Case	02
旋梭   Hook	08
压脚   Presser Foot	12
针板   Needle Plate	22
牙齿   Feed Dog	26
动定刀/分线片   Knives / Needle Protecting Patch	30
刀片   Knife	36
弯针   Looper	38
针夹头   Needle Clamp	40
针杆   Needle Bar	42
双针机针位   Needle Gauge For Double Needle	46
夹线器   Thread Tension	50
绕线器   Bobbin Winder	54
电磁铁   Solenoid	58
包缝连杆   Overlock Connecting Rod	60
剪线刀组   Thread Trimmer Asm	62
双开关   LED And Switch	64
上弯针滑杆   Upper Looper Holder Assy	66

## 辅件类 | Accessories

白油   Machine Oil	69
剪刀   Scissors	70
镊子   Tweezer	73
皮尺/卷尺   Tapeline	74
裁剪小套装   Tailor's Tool set	75
螺丝刀   Screwdriver	75
衣车斗   Clothing Basket	76
衣车灯   Sewing Lamp & Fan	76

## 下单系统 | Online Parts Ordering System

零件服务   Spare Parts Service	78
----------------------------	----

# 零件类

— Spare Parts —

**小身材 大能量**

杰克原厂零件

让您的机器始终保持出色状态

Small body, big power

Jack original parts

Keep your machine always in excellent condition



# 梭芯/梭壳

Bobbin / Bobbin Case

- 高强度合金材料，耐冲击、不变形，使用周期长
- 精湛工艺，对称精致圆孔设计，结构轻巧，过线更流畅
- 通用型零件，适配度更高，使用更高效

High-strength alloy material, impact resistance, no deformation, longer service life.  
Exquisite craftsmanship, symmetrical and refined round hole design, light structure, smoother threading.  
Universal parts, higher adaptability, more efficient to use.

- 高强度合金材料，原厂精品，使用寿命更长
- 精准加工，高品质处理，表面光洁、平滑
- 日本东和，品牌专供，品质保证

High-strength alloy material, original high quality, longer service life.  
Precision & high quality processing, smooth surface.  
Japan TOWA brand, brand exclusive supply, quality assurance.



◎ 耐冲击，不变形

◎ 圆孔光滑，过线流畅

◎ 通用型梭芯

Impact resistance, no deformation  
Smooth round hole, smooth threading  
Universal Bobbin

◎ 原厂品质，质量保障

◎ 精准加工，过线顺畅

Original quality, quality assurance  
Precise processing, smooth threading

## 平缝梭芯 Lockstitch Bobbin



名称: 通用梭芯

Description: Bobbin

代码/Part NO: 10118003

适配: 平缝系列

Machine Type: Lockstitch machine series



名称: 梭芯

Description: Bobbin

代码/Part NO: 14118002

适配: A5/A5-W/A6 (-D) 系列

Machine Type: A5/A5-W/A6 (-D) series

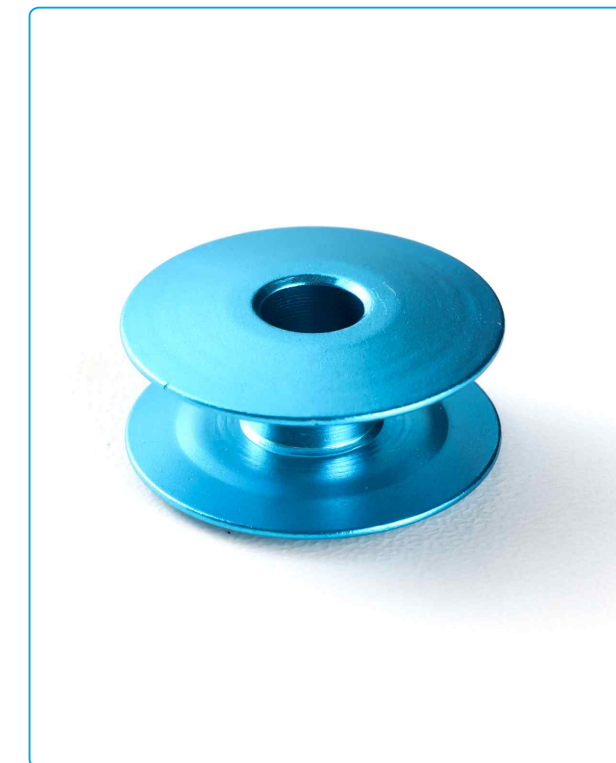

名称: 梭芯(1.3倍)

Description: Bobbin(1.3 Times)

代码/Part NO: 13818002

适配: A3/A4/A5/A4E/A6F(-P 系列)

Machine Type: A3/A4/A5/A4E/A6F(-P series)

## 双针/厚料梭芯 Double Needle/Heavy Duty Bobbin



名称: **双针机梭芯**

Description: Bobbin

代码/Part NO: 11618001

适配: JK-58420/58450/58420D/58450D

Machine Type: JK-58420/58450



名称: **大梭芯**

Description: Bobbin (Big)

代码/Part NO: 10818501

适配: 6380/80B/80C/90A/90C/100A/2001G/2030G/2060G

Machine Type: 6380/80B/80C/90A/90C/100A/2001G/2030G/2060G

## 特种机梭芯 Special Machine Bobbin



名称: **花样机梭芯**

Description: Bobbin

代码/Part NO: 41718004

适配: JK-T1310/T2210/T3020

Machine Type: JK-T1310/T2210/T3020



名称: **模板机梭芯(1.3倍)**

Description: Bobbin (1.3 Times)

代码/Part NO: 141818009

适配: MG-80AP/MS-90AP/MS-100AP/MT-90C

Machine Type: MG-80AP/MS-90AP/MS-100AP/MT-90C



名称: **模板机梭芯(2倍)**

Description: Bobbin (2 Times)

代码/Part NO: 41818621

适配: MG-80A/MS-90A/MS-100A

Machine Type: MG-80A/MS-90A/MS-100A

## 平缝梭壳 Lockstitch Bobbin Case



名称: **电脑车梭壳(进口)**

Description: Bobbin Case With Spring

代码/Part NO: 11218504

适配: 电脑平缝系列

Machine Type: Computerized lockstitch machine



名称: **普通/直驱梭壳**

Description: Bobbin Case Without Spring

代码/Part NO: 10118021

适配: 普通/直驱平缝系列

Machine Type: Ordinary/Direct Drive lockstitch machine



名称: **梭壳(进口)**

Description: Bobbin Case

代码/Part NO: 10118501

适配: JK-5558G

Machine Type: JK-5558G



名称: **梭壳(1.3倍)**

Description: Bobbin Case (1.3 Times)

代码/Part NO: 13818004

适配: A3/A4/A5/A4E/A6F(-P series)

Machine Type: A3/A4/A5/A4E/A6F(-P series)



名称: **梭壳(1.3倍) (进口)**

Description: Bobbin Case (1.3 Times)

代码/Part NO: 13818003

适配: A3/A4/A5/A4E/A6F(-P series)

Machine Type: A3/A4/A5/A4E/A6F(-P series)



## 厚料/双针梭壳 Heavy Duty/Double Needle Bobbin Case



名称: **梭壳**  
Description: Bobbin Case  
代码/Part NO: 155218005  
适配: JK-6691  
Machine Type: JK-6691



名称: **梭壳**  
Description: Bobbin Case  
代码/Part NO: 10818502  
适配: JK-609S/H2/H5/6380/F4-7  
Machine Type: JK-609S/H2/H5/6380/F4-7



名称: **梭壳(进口)**  
Description: Bobbin Case  
代码/Part NO: 809134  
适配: JK-58420D/G/J  
Machine Type: JK-58420D/G/J



名称: **梭壳**  
Description: Bobbin Case  
代码/Part NO: 809553  
适配: JK-58450D/G/J  
Machine Type: JK-58450D/G/J



名称: **梭壳(进口)**  
Description: Bobbin Case  
代码/Part NO: 808685  
适配: JK-58450D/G/J  
Machine Type: JK-58450D/G/J



名称: **梭壳**  
Description: Bobbin Case  
代码/Part NO: 809887  
适配: JK-58450B/C  
Machine Type: JK-58450B/C



名称: **梭壳**  
Description: Bobbin Case  
代码/Part NO: 12918029  
适配: JK-58450B/C  
Machine Type: JK-58450B/C



名称: **梭壳**  
Description: Bobbin Case  
代码/Part NO: 11818003  
适配: JK-58720  
Machine Type: JK-58720



名称: **梭壳(进口)**  
Description: Bobbin Case  
代码/Part NO: 810728  
适配: JK-58750D/G/J  
Machine Type: JK-58750D/G/J



名称: **梭壳**  
Description: Bobbin Case  
代码/Part NO: 12918030  
适配: JK-58750B/C  
Machine Type: JK-58750B/C



名称: **梭壳**  
Description: Bobbin Case  
代码/Part NO: 13618001  
适配: 6380/6390/H2/H5/A3-7/A4-7  
Machine Type: 6380/6390/H2/H5/A3-7/A4-7

## 特种机梭壳 Special Machine Bobbin Case



名称: **梭壳**  
Description: Bobbin Case  
代码/Part NO: 42218002  
适配: 80B/80C/90A/90C/100A  
Machine Type: 80B/80C/90A/90C/100A



名称: **梭壳**  
Description: Bobbin Case  
代码/Part NO: 41318003  
适配: JK-T1790系列  
Machine Type: JK-T1790 series



名称: **梭壳**  
Description: Bobbin Case  
代码/Part NO: 40318011  
适配: JK-T1900系列  
Machine Type: JK-T1900 series



名称: **梭壳**  
Description: Bobbin Case  
代码/Part NO: 42118003+42118001  
适配: JK-T5878-68/5878-78  
Machine Type: JK-T5878-68/5878-78



名称: **梭壳**  
Description: Bobbin Case  
代码/Part NO: 4021800100  
适配: JK-T781系列  
Machine Type: JK-T781 series



名称: **梭壳**  
Description: Bobbin Case  
代码/Part NO: 4171801700  
适配: JK-T1310/T2210/T3020  
Machine Type: JK-T1310/T2210/T3020

**旋梭**  
Hook

- 采用优良合金钢材质，加工精度高，防刮耐用、不易变形
- 特殊电镀技术，使用顺畅、不卡线、不断线，使用无噪音
- 每个旋梭，独立包装，且均印有防伪标志，方便您的查询

Excellent alloy steel, Precision processing, durable scratch resistance, no deformation.  
Special plating technology, smooth surface, no thread stuck & no thread broken, no noise.  
Each hook is individually packaged and printed with anti-counterfeiting mark, easy for refer.



◎ 精准加工，无噪音

◎ 不卡线、不断线

◎ 防伪标志，值得信赖

Precision processing, no noise  
No thread stuck & no thread broken  
Anti-counterfeiting mark, trustworthy

**平缝旋梭 Lockstitch Hook**



名称: **广濑中厚料旋梭**

Description: Hook Asm (Hirose)

代码/Part NO: 11418003

适配: 平缝机型 (除“-H”机型)

Machine Type: Lockstitch Machine (Except "H" series)



名称: **广濑厚料旋梭**

Description: Hirose Hook (Heavy Duty)

代码/Part NO: 11418004

适配: 平缝“-H”机型

Machine Type: Lockstitch machine "H" series



名称: **JK-7.94BTR 旋梭**

Description: 7.94BTR Hook

代码/Part NO: 809481

适配: 电脑车中厚料

Machine Type: Computerized lockstitch Machine (Medium Heavy Duty)



名称: **JK-7.94ATR 旋梭**

Description: 7.94ATR Hook

代码/Part NO: 809480

适配: 电脑车厚料

Machine Type: Computerized Lockstitch Machine (Heavy Duty)



名称: **JK-7.94A 旋梭**

Description: 7.94A Hook

代码/Part NO: 809478

适配: 普通车厚料

Machine Type: Ordinary Lockstitch Machine (Heavy Duty)



名称: **JK-7.94B 旋梭**

Description: 7.94B Hook

代码/Part NO: 809479

适配: 普通车中厚料

Machine Type: Ordinary Lockstitch Machine (Medium Heavy Duty)



**厚料/双针旋梭 Heavy Duty/Double Needle Hook**



名称: **大旋梭(厚料)**  
Description: Hook asm-(H)  
代码/Part NO: 10818001  
适配: 609S/H2/2002  
Machine Type: 609S/H2/2002

**特种机旋梭 Special Machine Hook**



名称: **模板机旋梭(1.3DLC)**  
Description: MS-90A Hook (1.3 Times DLC)  
代码/Part NO: 141818005  
适配: MS-90AP  
Machine Type: MS-90AP



名称: **双针机旋梭**  
Description: JK-58420D Hook Assy  
代码/Part NO: 1291801400  
适配: JK-58420D/G/J  
Machine Type: JK-58420D/G/J



名称: **双针机旋梭**  
Description: JK-58450D Hook Assy  
代码/Part NO: 1291801500  
适配: JK-58450D/G/J  
Machine Type: JK-58450D/G/J



名称: **双针机旋梭**  
Description: JK-58720D Hook Assy  
代码/Part NO: 1291801600  
适配: JK-58720D/G/J  
Machine Type: JK-58720D/G/J



名称: **双针机旋梭**  
Description: JK-58750D Hook Assy  
代码/Part NO: 1291801700  
适配: JK-58750D/G/J  
Machine Type: JK-58750D/G/J



名称: **模板机旋梭**  
Description: MS-90A Hook(Hirose)  
代码/Part NO: 41818101  
适配: MS-90A  
Machine Type: MS-90A



压脚

Presser foot

- ◎ 精密加工, 过布顺畅
- ◎ 流线型设计, 线迹美观
- ◎ 硬质合金刀片, 锋利耐用
- ◎ 表面电镀处理, 防锈能力强, 不伤布

Precise processing, smooth sewing  
Streamline design, nice thread stitch  
Hard alloy knife, sharp and durable  
Surface electroplate, strong anti-rust, harmless to fabric

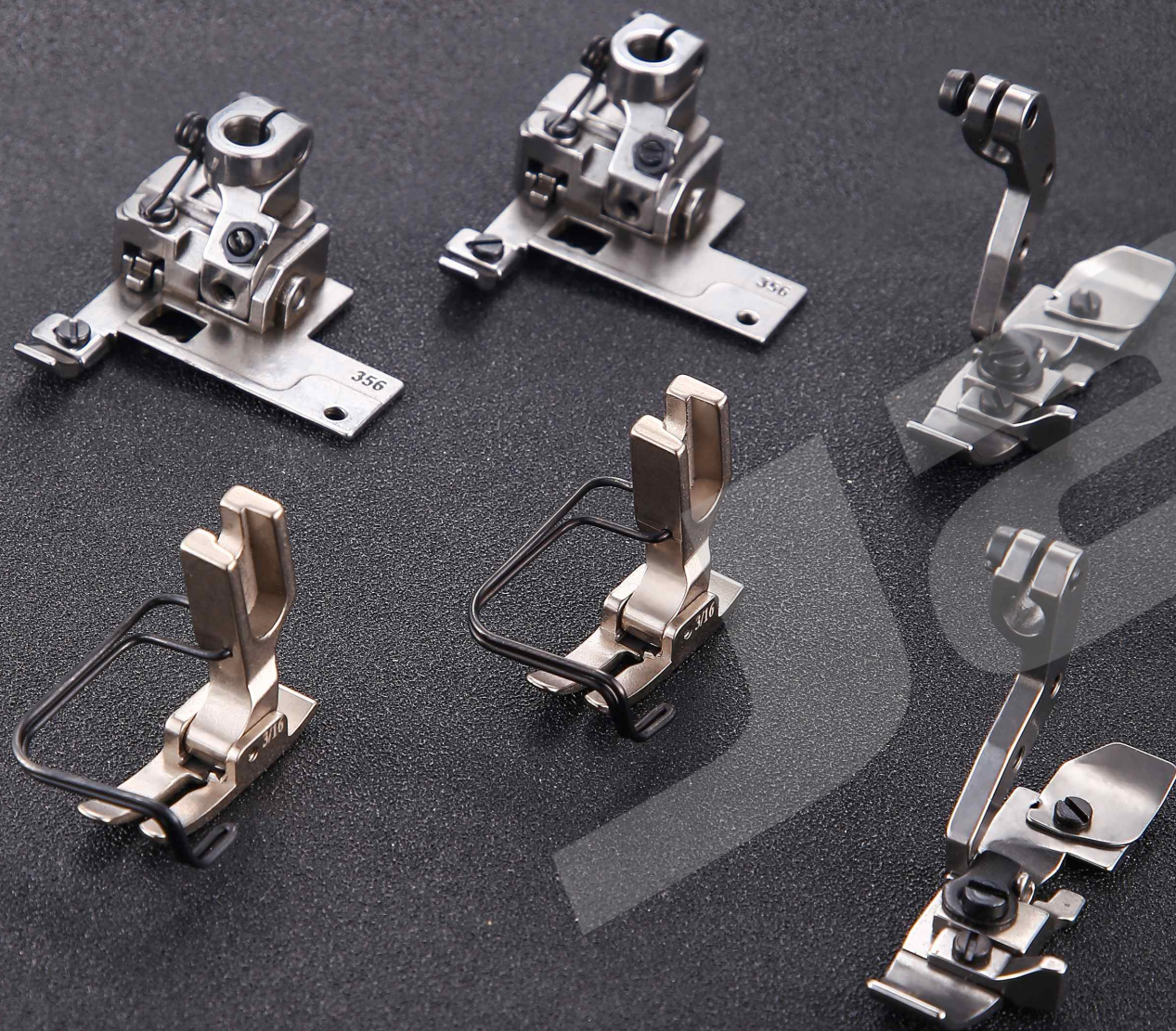

平缝压脚 Lockstitch Presser Foot



名称: **压脚组件(厚料)**  
Description: Presser Foot (Heavy Duty)  
代码/Part NO: 1131600100  
适配: 平缝机厚料机型 (除-N以外)  
Machine Type: All heavy duty lockstitch series (Except N type)



名称: **压脚组件(薄料)**  
Description: Presser Foot (Light Duty)  
代码/Part NO: 1131600600  
适配: 平缝机机型 (除厚料机型外和-N以外)  
Machine Type: All normal lockstitch series (Except heavy duty & N type)



名称: **塑料压脚**  
Description: Plastic Presser Foot  
代码/Part NO: 811049  
适配: 平缝机通用  
Machine Type: All lockstitch machine series



名称: **压脚组件**  
Description: Presser Foot  
代码/Part NO: 1131600300  
适配: 平缝机通用  
Machine Type: All lockstitch machine series



名称: **同步车小压脚**  
Description: Inside Presser Foot  
代码/Part NO: 13516001  
适配: 6380/H2/H5  
Machine Type: 6380/H2/H5



## 全钢压脚 Steel Presser Foot



名称: **P36N**  
**单边右孔全钢压脚**

Description: Steel Presser Foot P36N  
代 码/Part NO: 811296  
适 配: 平缝机通用  
Machine Type: All lockstitch machine series



名称: **P36LN** 单边左孔全钢压脚  
Description: Steel Presser Foot P36LN  
代 码/Part NO: 811297  
适 配: 平缝机通用  
Machine Type: All lockstitch machine series



名称: **CR1/16N** 右高左低全钢压脚  
Description: Steel Presser Foot CR1/16N  
代 码/Part NO: 811298  
适 配: 平缝机通用  
Machine Type: All lockstitch machine series



名称: **CR1/32N** 右高左低全钢压脚  
Description: Steel Presser Foot CR1/32N  
代 码/Part NO: 811299  
适 配: 平缝机通用  
Machine Type: All lockstitch machine series



名称: **CL1/16N** 左高右低全钢压脚  
Description: Steel Presser Foot CL1/16N  
代 码/Part NO: 811300  
适 配: 平缝机通用  
Machine Type: All lockstitch machine series



名称: **CL1/32N** 左高右低全钢压脚  
Description: Steel Presser Foot CL1/32N  
代 码/Part NO: 811301  
适 配: 平缝机通用  
Machine Type: All lockstitch machine series



名称: **P363** 牙签全钢压脚  
Description: Steel Presser Foot P363  
代 码/Part NO: 811302  
适 配: 平缝机通用  
Machine Type: All lockstitch machine series



名称: **P127** 全钢压脚  
Description: Steel Presser Foot P127  
代 码/Part NO: 811303  
适 配: 平缝机通用  
Machine Type: All lockstitch machine series



名称: **P52** 可调打折压脚  
Description: Steel Presser Foot P52  
代 码/Part NO: 811304  
适 配: 平缝机通用  
Machine Type: All lockstitch machine series

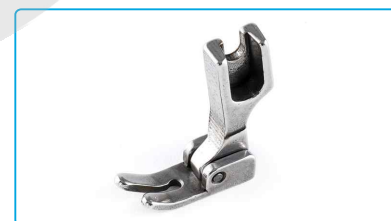

名称: **P58N** 全钢压脚  
Description: Steel Presser Foot P58N  
代 码/Part NO: 811305  
适 配: 平缝机通用  
Machine Type: All lockstitch machine series

## 塑料压脚 Plastic Presser Foot



名称: **MT-18AAA级**  
**(塑料平压脚)**

Description: MT-18AAA Flat Presser Foot  
代 码/Part NO: 811278  
适 配: 平缝机通用  
Machine Type: All lockstitch machine series



名称: **T360** (塑料右窄平压脚)  
Description: T360 Right Narrow Flat Presser Foot  
代 码/Part NO: 811279  
适 配: 平缝机通用  
Machine Type: All lockstitch machine series



名称: **T361** (塑料左窄平压脚)  
Description: T361 Left Narrow Flat Presser Foot  
代 码/Part NO: 811280  
适 配: 平缝机通用  
Machine Type: All lockstitch machine series



名称: **TCR** 双层右高左低1/16N塑料压脚  
Description: TCR presser foot 1/16N  
代 码/Part NO: 811284  
适 配: 平缝机通用  
Machine Type: All lockstitch machine series

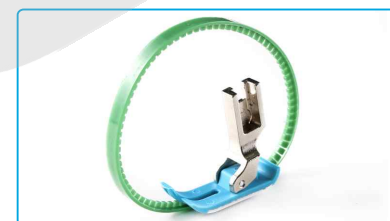

名称: **TM-18** 塑料左滚轮压脚  
Description: TM-18 Presser Foot With Left Roller  
代 码/Part NO: 811282  
适 配: 平缝机通用  
Machine Type: All lockstitch machine series

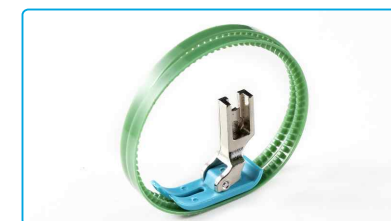

名称: **TM-18** 塑料双滚轮压脚  
Description: TM-18 Presser Foot With Double Roller  
代 码/Part NO: 811283  
适 配: 平缝机通用  
Machine Type: All lockstitch machine series



名称: **TM-18** 塑料右滚轮压脚  
Description: TM-18 Presser Foot With Right Roller  
代 码/Part NO: 811281  
适 配: 平缝机通用  
Machine Type: All lockstitch machine series



名称: **TCR** 双层右高左低1/32N塑料压脚  
Description: TCR Presser Foot 1/32N  
代 码/Part NO: 811285  
适 配: 平缝机通用  
Machine Type: All lockstitch machine series



名称: **TCR** 右高左低1/4塑料压脚  
Description: TCR Presser Foot 1/4  
代 码/Part NO: 811286  
适 配: 平缝机通用  
Machine Type: All lockstitch machine series

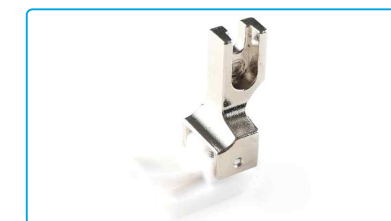

名称: **TCR** 右高左低1/8塑料压脚  
Description: TCR Presser Foot 1/8  
代 码/Part NO: 811287  
适 配: 平缝机通用  
Machine Type: All lockstitch machine series



## A5-N带刀压脚 A5-N Presser Foot With Knife



名称: **TCR 右高左低1/16N塑料压脚**  
Description: TCR Presser Foot 1/16N  
代 码/Part NO: 811288  
适 配: 平缝机通用  
Machine Type: All lockstitch machine series



名称: **TCR 右高左低3/16塑料压脚**  
Description: TCR Presser Foot 3/16  
代 码/Part NO: 811289  
适 配: 平缝机通用  
Machine Type: All lockstitch machine series



名称: **TCR 右高左低1/32N塑料压脚**  
Description: TCR Presser Foot 1/32N  
代 码/Part NO: 811290  
适 配: 平缝机通用  
Machine Type: All lockstitch machine series



名称: **TCL 双层右高左低1/16N塑料压脚**  
Description: TCL Presser Foot 1/16N  
代 码/Part NO: 811291  
适 配: 平缝机通用  
Machine Type: All lockstitch machine series



名称: **TCL 双层右高左低1/32N塑料压脚**  
Description: TCL Presser Foot 1/32N  
代 码/Part NO: 811292  
适 配: 平缝机通用  
Machine Type: All lockstitch machine series



名称: **TCL 左高右低1/8塑料压脚**  
Description: TCL Presser Foot 1/8  
代 码/Part NO: 811293  
适 配: 平缝机通用  
Machine Type: All lockstitch machine series



名称: **TCL 左高右低1/16N塑料压脚**  
Description: TCL Presser Foot 1/16N  
代 码/Part NO: 811294  
适 配: 平缝机通用  
Machine Type: All lockstitch machine series



名称: **TCL 左高右低1/32N塑料压脚**  
Description: TCL Presser Foot 1/32N  
代 码/Part NO: 811295  
适 配: 平缝机通用  
Machine Type: All lockstitch machine series



名称: **高低压脚组件1/32LN(左高右低)**  
Description: Presser Foot With Knife (CL1/32N)  
代 码/Part NO: 1411600200  
适 配: A5-N  
Machine Type: A5-N



名称: **单边带刀压脚组件**  
Description: Presser Foot With Knife (P36LN)  
代 码/Part NO: 1411600300  
适 配: A5-N  
Machine Type: A5-N



名称: **短距缝带刀压脚组件**  
Description: Presser Foot With Knife (Short Distance Stitch)  
代 码/Part NO: 1411600400  
适 配: A5-N  
Machine Type: A5-N



名称: **高低压脚组件CL1/16N(左高右低)**  
Description: Presser Foot with Knife (CL1/16N)  
代 码/Part NO: 1381601300  
适 配: A5-N  
Machine Type: A5-N



名称: **带刀压脚组件(3/16)**  
Description: Presser Foot With Knife (3/16)  
代 码/Part NO: 1411601000  
适 配: A5-N  
Machine Type: A5-N



名称: **高低压脚CR1/32组件(右高左底)**  
Description: Presser Foot With Knife (CR1/32N)  
代 码/Part NO: 1401600300  
适 配: A5-N  
Machine Type: A5-N



名称: **高低压脚组件CR1/16N(右高左低)**  
Description: Presser Foot With Knife (CR1/16N)  
代 码/Part NO: 1381601500  
适 配: A5-N  
Machine Type: A5-N



名称: **带刀压脚组件**  
Description: Presser Foot With Knife  
代 码/Part NO: 1411600100  
适 配: A5-N  
Machine Type: A5-N



名称: **塑料带刀压脚**  
Description: Plastic Presser Foot With Knife  
代 码/Part NO: 11411600100  
适 配: A5-N  
Machine Type: A5-N

## A6F压脚 A6F Presser Foot



名称: **左单边压脚(P36LN-NF)**  
Description: (P36LN-NF) Left Unilateral Presser Foot  
代码/Part NO: 114416002  
适配: A6F  
Machine Type: A6F



名称: **右单边压脚(P36N-NF)**  
Description: (P36N-NF) Right Unilateral Presser Foot  
代码/Part NO: 114416003  
适配: A6F  
Machine Type: A6F



名称: **左高右低压脚 (CR1/16NNF)**  
Description: CR1/16NNF Presser Foot  
代码/Part NO: 114416004  
适配: A6F  
Machine Type: A6F



名称: **左低右高压脚 (CL1/16NNF)**  
Description: CL1/16NNF Presser Foot  
代码/Part NO: 114416005  
适配: A6F  
Machine Type: A6F



名称: **左高右低压脚 (CR1/32NNF)**  
Description: CR1/32NNF Presser Foot  
代码/Part NO: 114416006  
适配: A6F  
Machine Type: A6F



名称: **左低右高压脚 (CL1/32NNF)**  
Description: CL1/32NNF Presser Foot  
代码/Part NO: 114416007  
适配: A6F  
Machine Type: A6F



名称: **左低右高压脚 (宽边)(CRE1/16NNF)**  
Description: CRE1/16NNF Presser Foot (Wide Side)  
代码/Part NO: 114416008  
适配: A6F  
Machine Type: A6F



名称: **左低右高压脚 (宽边)(CLE1/16NNF)**  
Description: CLE1/16NNF Presser Foot (Wide Side)  
代码/Part NO: 114416009  
适配: A6F  
Machine Type: A6F



名称: **左高右低压脚(宽边) (CRE1/32NNF)**  
Description: CRE1/32NNF Presser Foot (Wide Side)  
代码/Part NO: 114416010  
适配: A6F  
Machine Type: A6F



名称: **左低右高压脚 (宽边)(CLE1/32NNF)**  
Description: CLE1/32NNF Presser Foot (Wide Side)  
代码/Part NO: 114416011  
适配: A6F  
Machine Type: A6F



名称: **宽压脚组件**  
Description: Wide Presser Foot  
代码/Part NO: 11441600100  
适配: A6F  
Machine Type: A6F

## 包缝压脚 Overlock Presser Foot

### 三线 3 Thread



名称: **压脚组件**  
Description: Presser Foot  
代码/Part NO: 2071601000  
适配: E3-3-M1-15  
Machine Type: E3-3-M1-15



名称: **压脚组件**  
Description: Presser Foot  
代码/Part NO: 12121600500  
适配: E3/E4/C5/E4S/C5S系列  
02/233机型  
Machine Type: 02/233 type of E3/E4/C5/E4S/C5S series



名称: **压脚组件**  
Description: Presser Foot  
代码/Part NO: 12121600600  
适配: E4/C4/C5/E4S系列  
-32R2/223机型  
Machine Type: 32R2/223 type of E4/C4/C5/E4S series

### 四线 4 Thread

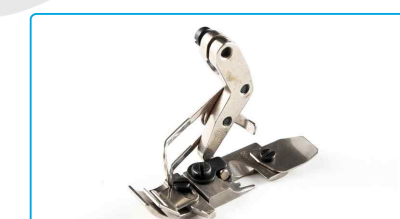

名称: **压脚组件**  
Description: Presser Foot  
代码/Part NO: 12011600300  
适配: 804D-M2-24 E3-4-M2-24  
Machine Type: 804D-M2-24 E3-4-M2-24



名称: **压脚组件**  
Description: Presser Foot  
代码/Part NO: 12081600100  
适配: 797T/798T系列  
Machine Type: 797T/798T series



名称: **压脚组件**  
Description: Presser Foot  
代码/Part NO: 2081600300  
适配: 798T系列  
Machine Type: 798T series



名称: **压脚组件(倒回缝)**  
Description: Presser Foot (BK)  
代码/Part NO: 12121600800  
适配: E3-4-M5-23, E4-4-83/323  
Machine Type: E3-4-M5-23 E4-4-83/323



名称: **压脚组件**  
Description: Presser Foot  
代码/Part NO: 2071609400  
适配: C3/C4/C5/C5S/C5F/C6/C8系列-M03/333机型  
Machine Type: M03/333 type of C3/C4/C5/C5S/C5F/C6/C8 series



名称: **压脚组件**  
Description: Presser Foot  
代码/Part NO: 12121605400  
适配: 798D/E4/E4S/C4/C5/C5S-BK  
Machine Type: 798D/E4/E4S/C4/C5/C5S-BK



五线 5 Thread



名称: **压脚组件(薄料)**  
Description: Presser Foot ( Light Duty)  
代 码/Part NO: 20716050  
适 配: E4-5-02A/233  
Machine Type: E4-5-02A/233



名称: **压脚组件(70款)**  
Description: Presser Foot (70 Type)  
代 码/Part NO: 2081600700  
适 配: 798T  
Machine Type: 798T



名称: **压脚组件(厚料)**  
Description: Presser Foot (Heavy Duty)  
代 码/Part NO: 2081600600  
适 配: 798T-A04/435机型  
Machine Type: JK-798T-5-516-A04/435



名称: **压脚组件**  
Description: Presser Foot  
代 码/Part NO: 2080101400  
适 配: JK-798TDI-5-516-03/333  
JK-798TE-5-516-03/333  
Machine Type: JK-798TDI-5-516-03/333  
JK-798TE-5-516-03/333



名称: **压脚组件**  
Description: Presser Foot  
代 码/Part NO: 12121600900  
适 配: 798D/798E/905E/E3/E4/  
C3/C4/C5/C5S/C6/C8  
Machine Type: 798D/798E/905E/E3/E4/  
C3/C4/C5/C5S/C6/C8



名称: **压脚组件(70款)**  
Description: Presser Foot (70 Type)  
代 码/Part NO: 12121601000  
适 配: 798D/798E/805D/905E/  
E3/E4/C3/C4/C5  
Machine Type: 798D/798E/805D/905E/  
E3/E4/C3/C4/C5



名称: **压脚组件(厚料)**  
Description: Presser Foot (Heavy Duty)  
代 码/Part NO: 2061604100  
适 配: C3/C4/E4S/C5/C5S/C6/C8-M04/435  
Machine Type: C3/C4/E4S/C5/C5S/C6/C8-M04/435



名称: **压脚组件(厚料)**  
Description: Presser Foot (Heavy Duty)  
代 码/Part NO: 12121601100  
适 配: C3/C4/E4/C5/C5S/C6/C8-A04/435  
Machine Type: C3/C4/E4/C5/C5S/C6/C8-A04/435

绷缝压脚 Interlock Presser Foot



名称: **压脚(364)**  
Description: Presser Foot (364)  
代 码/Part NO: 30116006  
适 配: W4/W4S/ K4/K5系列  
02BB/23BB机型  
Machine Type: 02BB/23BB type  
for W4/W4S/K4/K5 series

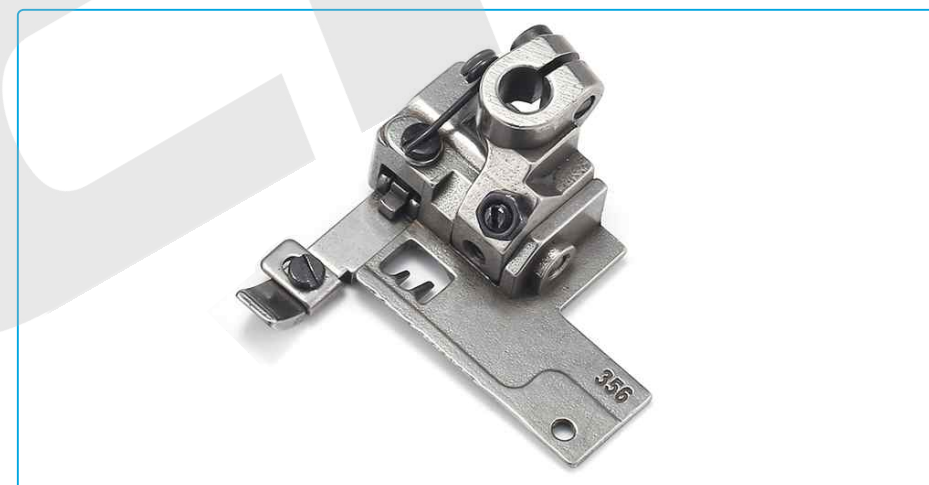

名称: **压脚(356)**  
Description: Presser Foot (356)  
代 码/Part NO: 30116005  
适 配: W4/W4S/ K4/K5系列  
02BB/23BB机型  
Machine Type: 02BB/23BB type  
for W4/W4S/K4/K5 series



名称: **压脚组件(356)**  
Description: Presser foot ( 356)  
代 码/Part NO: 3011601300  
适 配: 8670/W4  
Machine Type: 8670/W4



名称: **压脚组件(356)**  
Description: Presser foot ( 356)  
代 码/Part NO: 3021601000  
适 配: 8670/K4  
Machine Type: 8670/K4



# 针板

Needle Plate

- 针板厚度2.6mm，强度韧性好，耐磨不易断裂；选用20CrMo材料，韧性足，强度高，耐磨不易断形
- 电镀均匀，不易生锈、划伤
- 化学定位孔设计，定位精准
- 落针孔口光滑无毛刺

With a proper thickness of 2.6mm and selected material of 20CrMo, it has good toughness and high strength, not easy to break. Electroplated evenly on the surface, not easy to get rusty and scratch. Chemical positioning hole design, accurate positioning. It is smooth inside and around the needle hole without burr.



◎ 韧性足，电镀均匀，使用寿命长

◎ 定位精准，表面光滑

Good toughness and high strength  
Electroplated evenly on the surface position well Smooth surface

## 平缝针板 Lockstitch Needle Plate



名称: **针板(扩大缝绉范围)**  
Description: Needle Plate (Expand Sewing Scope)  
代码/Part NO: 11414006  
适配: 平缝机通用 (除A6F)  
Machine Type: All Lockstitch machine (Except A6F)



名称: **针板**  
Description: Needle Plate  
代码/Part NO: 11315001  
适配: 平缝机通用 (除A6F)  
Machine Type: All Lockstitch machine (Except A6F)



名称: **针板**  
Description: Needle Plate  
代码/Part NO: 13615003  
适配: 平缝HL-7  
Machine Type: Lockstitch machine HL-7



名称: **针板**  
Description: Needle Plate  
代码/Part NO: 13815011  
适配: A3E/A4E/A5E/A5/A6/A7  
Machine Type: A3E/A4E/A5E/A5/A6/A7



名称: **针板**  
Description: Needle Plate  
代码/Part NO: 13515001  
适配: JK-6380/6390/H2/H5/H6  
Machine Type: JK-6380/6390/H2/H5/H6



名称: **针板**  
Description: Needle Plate  
代码/Part NO: 10815001  
适配: JK-6380/6390/H2/H5/H6  
Machine Type: JK-6380/6390/H2/H5/H6

## 包缝针板 Overlock Needle Plate

三线 3 Thread



名称: **针板**  
Description: Needle Plate  
代码/Part NO: 20115001  
适配: E3-3-M2-04  
Machine Type: E3-3-M2-04



名称: **针板**  
Description: Needle Plate  
代码/Part NO: 20715203  
适配: C3/C4/C5/C5S系列02/233机型  
Machine Type: 02/233 type for C3/C4/C5/C5S series



名称: **针板(倒回缝)**  
Description: Needle Plate (BK)  
代码/Part NO: 20715019  
适配: E4/E4S-3-82/233  
Machine Type: E4/E4S-3-82/233



名称: **针板**  
Description: Needle Plate  
代码/Part NO: 20715005  
适配: E4/E4S-3-02/233  
Machine Type: E4/E4S-3-02/233



名称: **针板**  
Description: Needle Plate  
代码/Part NO: 20715010  
适配: E4/E4S-3-32R2/223  
Machine Type: E4/E4S-3-32R2/223



四线 4 Thread

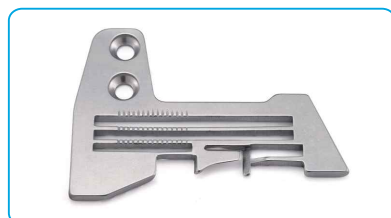

名称: 针板  
Description: Needle Plate  
代码/Part NO: 20115002  
适配: E3-4-M2-24  
Machine Type: E3-4-M2-24



名称: 针板  
Description: Needle Plate  
代码/Part NO: 20715201  
适配: 798TDI/C3/E4  
Machine Type: 798TDI/C3/E4



名称: 针板  
Description: Needle Plate  
代码/Part NO: 20715002  
适配: 798TDI/C3/E4  
Machine Type: 798TDI/C3/E4

五线 5 Thread



名称: 针板(厚料)  
Description: Needle Plate (Heavy Duty)  
代码/Part NO: 20715206  
适配: 798TE/C3/C4  
Machine Type: 798TE/C3/C4



名称: 针板  
Description: Needle Plate  
代码/Part NO: 20115008  
适配: E3-5-M2-55  
Machine Type: E3-5-M2-55



名称: 针板  
Description: Needle Plate  
代码/Part NO: 20715204  
适配: 798TE/C3/C4/C5  
Machine Type: 798TE/C3/C4/C5



名称: 针板  
Description: Needle Plate  
代码/Part NO: 20115003  
适配: E3-5-M2-35  
Machine Type: E3-5-M2-35



名称: 针板(70款)  
Description: Needle Plate (70 Type)  
代码/Part NO: 20715016  
适配: 798TDI/E4/E4S  
Machine Type: 798TDI/E4/E4S



名称: 针板  
Description: Needle Plate  
代码/Part NO: 20715008  
适配: 798TDI/E4/E4S  
Machine Type: 798TDI/E4/E4S



名称: 针板(厚料)  
Description: Needle Plate (Heavy Duty)  
代码/Part NO: 20715050  
适配: 798TDI/E4/E4S  
Machine Type: 798TDI/E4/E4S



名称: 针板(70款)  
Description: Needle Plate (70 Type)  
代码/Part NO: 20715205  
适配: 包缝C3/C4/C5  
Machine Type: C3/C4/C5

绷缝针板 Interlock Needle Plate



名称: 针板(356) (薄料)  
Description: Needle Plate (356, Light Duty)  
代码/Part NO: 30115067  
适配: W4/W4S/K4/K5系列-01GB机型  
Machine Type: 01GB type for W4/W4S/K4/K5 series



名称: 针板(364) (薄料)  
Description: Needle Plate (364, Light Duty)  
代码/Part NO: 30115068  
适配: W4/W4S/K4/K5系列-01GB机型  
Machine Type: 01GB type for W4/W4S/K4/K5 series

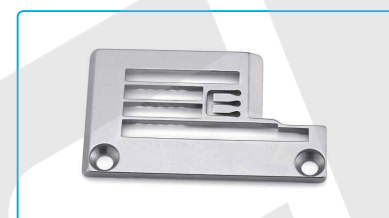

名称: 针板(356)  
Description: Needle Plate (356)  
代码/Part NO: 30115006  
适配: W4/W4S/K4/K5系列-02BB机型  
Machine Type: 02BB type for W4/W4S/K4/K5 series



名称: 针板(364)  
Description: Needle Plate (364)  
代码/Part NO: 30115007  
适配: W4/W4S/K4/K5系列-02BB机型  
Machine Type: 02BB type for W4/W4S/K4/K5 series



名称: 针板(356)  
Description: Needle Plate (356)  
代码/Part NO: 30115045  
适配: W4/W4S系列-23BB机型  
Machine Type: 23BB type for W4/W4S series



名称: 针板(356) (厚料)  
Description: Needle Plate (356, Heavy Duty)  
代码/Part NO: 30115002  
适配: W4/W4S/K4/K5系列01GB厚料机型  
Machine Type: 01GB heavy duty type for W4/W4S/K4/K5 series



名称: 针板(364) (厚料)  
Description: Needle Plate (364, Heavy Duty)  
代码/Part NO: 30115003  
适配: W4/W4S/K4/K5系列01GB厚料机型  
Machine Type: 01GB heavy duty type for W4/W4S/K4/K5 series



名称: 针板(356)  
Description: Needle Plate (356)  
代码/Part NO: 31015001  
适配: K4/K5系列-35AC机型  
Machine Type: 35AC type for K4/K5 series



名称: 针板(01CB) (356)  
Description: Needle Plate (01CB,356)  
代码/Part NO: 30715004  
适配: 8670系列-01CB机型  
Machine Type: 01CB type for 8670 series



名称: 针板(01CB) (364)  
Description: Needle Plate (01CB,364)  
代码/Part NO: 30715006  
适配: 8670系列-01CB机型  
Machine Type: 01CB type for 8670 series



名称: 针板(364)  
Description: Needle Plate (364)  
代码/Part NO: 31015002  
适配: K4/K5系列-35AC机型  
Machine Type: 35AC type for K4/K5 series



牙齿

Feed Dog

◎ 精密加工, 送料平稳、不跑偏

◎ 高防腐, 耐压磨, 使用寿命长

Precision processing, stable feeding, no deviation

High anticorrosion, pressure grinding, longer service life

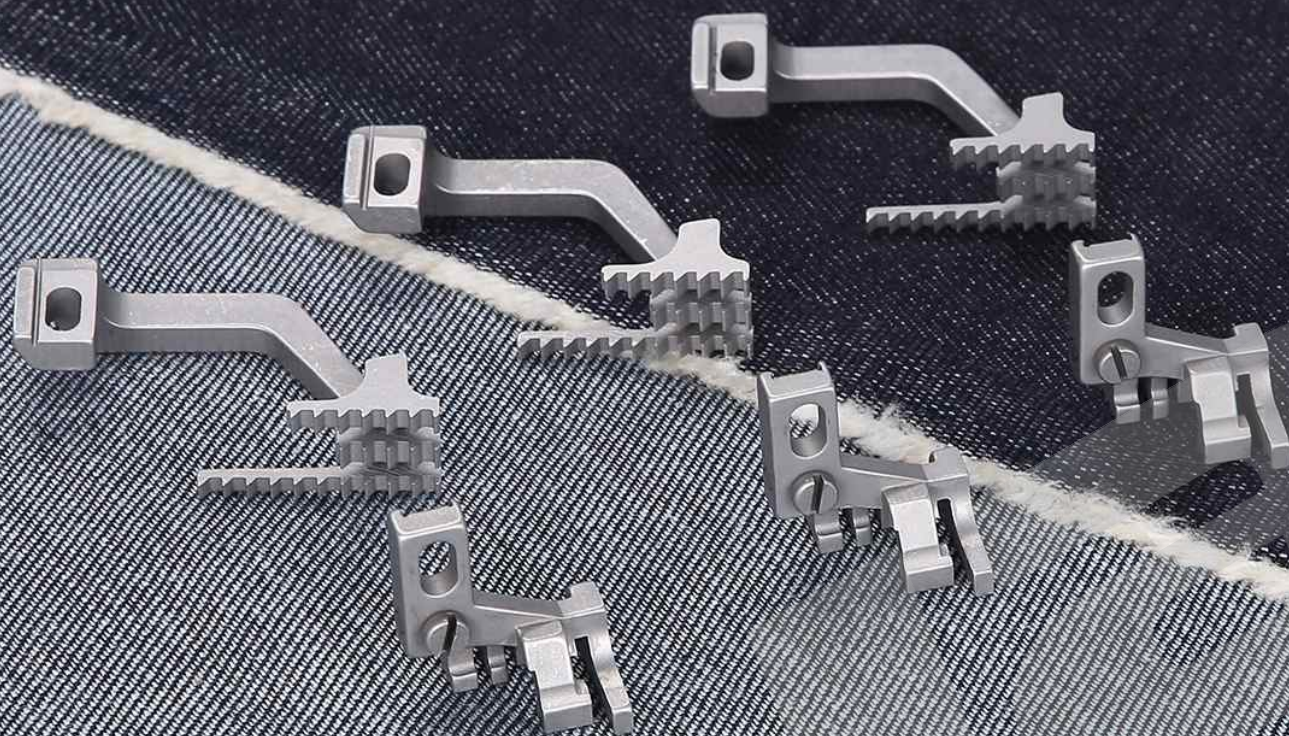

平缝机牙齿 Lockstitch Feed Dog

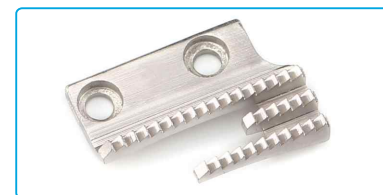

名称: 送料牙  
Description: Feed Dog  
代码/Part NO: 11414001  
适配: 平缝 "-7" 机型  
Machine Type: Lockstitch "-7" Series



名称: 送料牙  
Description: Feed Dog  
代码/Part NO: 11414002  
适配: 平缝机 (除"-H"-7" A6F"机型)  
Machine Type: Lockstitch (Except "-H" "-7" "A6F" model)



名称: 送料牙  
Description: Feed Dog  
代码/Part NO: 11314001  
适配: 平缝机 "-H" 机型 (除A6F外)  
Machine Type: Lockstitch "-H" series (Except "A6F")



名称: 送料牙  
Description: Feed Dog  
代码/Part NO: 13814005  
适配: A3E/A4E/A5E/A5/A6/A7  
Machine Type: A3E/A4E/A5E/A5/A6/A7

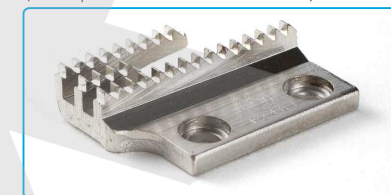

名称: 送布牙  
Description: Feed Dog  
代码/Part NO: 13614003  
适配: JK-6380/6390/H2/H5/2001G  
Machine Type: JK-6380/6390/H2/H5/2001G

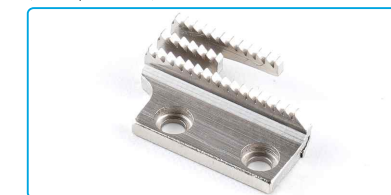

名称: 送布牙  
Description: Feed Dog  
代码/Part NO: 13514001  
适配: JK-6380/6390/H2/H5  
Machine Type: JK-6380/6390/H2/H5



名称: 送布牙  
Description: Feed Dog  
代码/Part NO: 10114051  
适配: JK-609S/F4-HL-7  
Machine Type: JK-609S/F4-HL-7



名称: 送料牙  
Description: Feed Dog  
代码/Part NO: 10814001  
适配: F4-7  
Machine Type: F4-7

包缝机牙齿 Overlock Feed Dog

三线 3 Thread



名称: 送料组件  
Description: Feed Dog Assy  
代码/Part NO: 2011401800  
适配: 803-M1-15 E3-3-M1-15  
Machine Type: 803-M1-15 E3-3-M1-15



名称: 送料组件  
Description: Feed Dog Assy  
代码/Part NO: 20714007/20714008  
适配: 798D/903E/E4/C4/C5  
Machine Type: 798D/903E/E4/C4/C5



名称: 牙齿组件(倒回缝)  
Description: Feed Dog Assy (BK)  
代码/Part NO: 2071402000  
适配: 798D-3-82/233 E4-3-82/233  
Machine Type: 798D-3-82/233 E4-3-82/233



**三/四线 3 & 4 Thread**



名称: **送料组件**  
Description: Feed Dog Assy  
代码/Part NO: 2011402100  
适配: E3系列M5机型  
Machine Type: M5 type for E3 series



名称: **送料组件**  
Description: Feed Dog Assy  
代码/Part NO: 2011401700  
适配: E3系列M2机型  
Machine Type: M2 type for E3 series



名称: **牙齿组件**  
Description: Feed Dog Assy  
代码/Part NO: 2071400100  
适配: E4/E4S/C3/C4/C5/C5F/C6系列M03/333(02/233)机型  
Machine Type: M03/333(02/233) type for E4/E4S/C3/C4/C5/C5F/C6 series

**五线 5 Thread**



名称: **牙齿组件**  
Description: Feed Dog Assy  
代码/Part NO: 2071400400  
适配: E4/E4S/C3/C4/C5/C5F/C6/C8系列-03/333机型  
Machine Type: 03/333 type for E4/E4S/C3/C4/C5/C5F/C6/C8 series



名称: **牙齿组件**  
Description: Feed Dog Assy  
代码/Part NO: 2011402000  
适配: E3-5×2-56  
Machine Type: E3-5×2-56



名称: **牙齿组件**  
Description: Feed Dog Assy  
代码/Part NO: 2011401900  
适配: E3-5-M2-35  
Machine Type: E3-5-M2-35



名称: **牙齿组件(70款)**  
Description: Feed Dog Assy (70 Type)  
代码/Part NO: 2071401700  
适配: E4/E4S/C3/C4/C5/C5S/C5F/C6/C8系列-03/233机型  
Machine Type: 03/233 type for E4/E4S/C3/C4/C5/C5S/C5F/C6/C8 series



名称: **牙齿组件(厚料)**  
Description: Feed Dog Assy (Heavy Duty)  
代码/Part NO: 2071405200  
适配: E4/E4S/C3/C4/C5/C5S/C5F/C6/C8系列-A04/435机型  
Machine Type: A04/435 type for E4/E4S/C3/C4/C5/C5S/C5F/C6/C8 series

**绷缝机牙齿 Interlock Feed Dog**



名称: **牙齿组件**  
Description: Feed Dog Assy  
代码/Part NO: 3011400300  
适配: W4S系列23BB机型  
Machine Type: 23BB type for W4S series

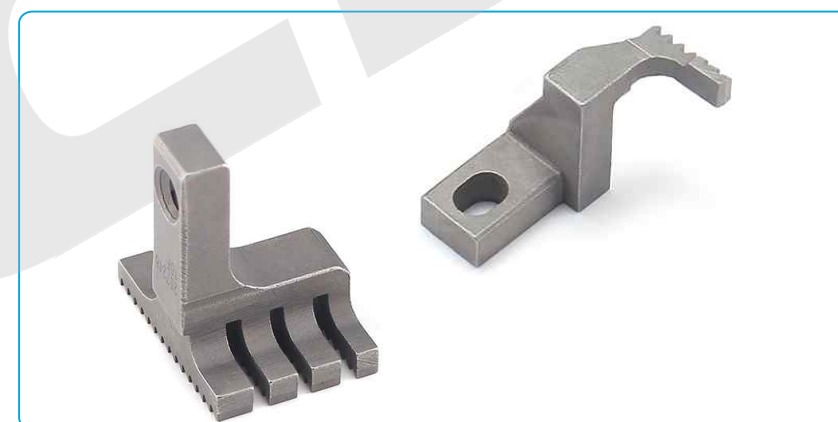

名称: **牙齿组件**  
Description: Feed Dog Assy  
代码/Part NO: 30214008 + 30214009  
适配: W4/W4S/K4/K5系列-02BB机型  
Machine Type: 02BB type for W4/W4S/K4/K5 series



名称: **牙齿组件**  
Description: Feed Dog Assy  
代码/Part No: 30214016 + 30214017  
适配: K4/K5系列-35AC机型  
Machine Type: 35AC type for K4/K5 series

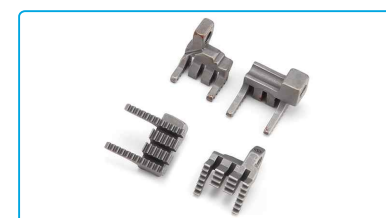

名称: **牙齿组件**  
Description: Feed Dog Assy  
代码/Part No: 30714003 + 30714004  
适配: 8670系列-01CB机型  
Machine Type: 01CB type for 8670 series



名称: **牙齿组件**  
Description: Feed Dog Assy  
代码/Part No: 30714001 + 30714002  
适配: 8670系列-03FB机型  
Machine Type: 03FB type for 8670 series



名称: **牙齿组件**  
Description: Feed Dog Assy  
代码/Part NO: 3011400200  
适配: W4/W4S系列-23GB机型  
Machine Type: 23GB type for W4/W4S series



## 动定刀/分线片

Knives / Needle Protecting Patch

- ◎ 高质量原料
- ◎ 硬度高，耐用更持久
- ◎ 产品锋利，韧性好，效率高

High quality of raw material  
High hardness, more durable life time  
Sharp knife with strong toughness, high efficient

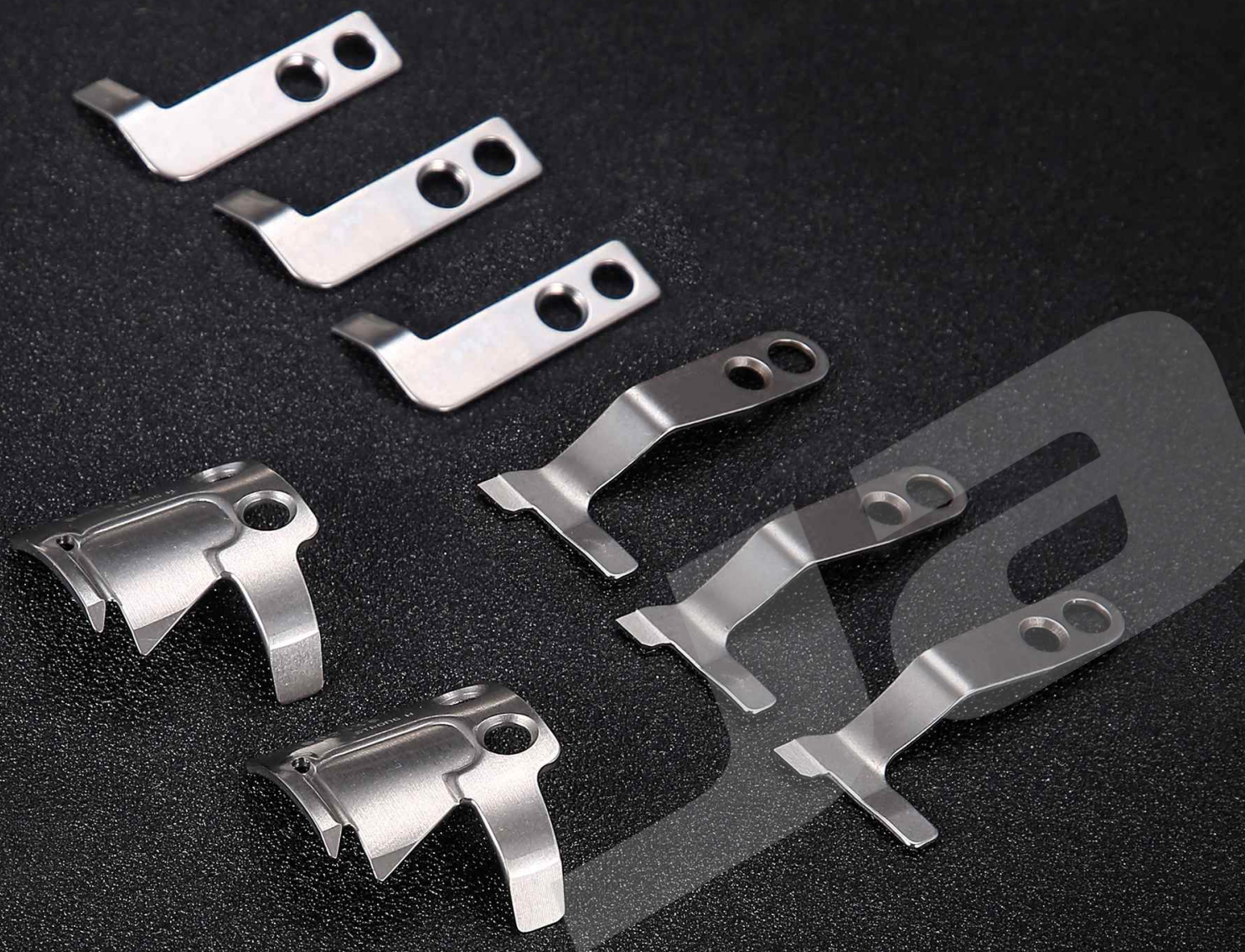

## 平缝动定刀 Lockstitch Knife



名称: **辅助动刀**  
Description: Auxiliary Knife  
代码/Part NO: 14119002  
适配: A5-W/A5E-W/A6F/A8<sup>+</sup>/A10<sup>+</sup>  
Machine Type: A5-W/A5E-W/A6F/A8<sup>+</sup>/A10<sup>+</sup>



名称: **辅助动刀(厚料双刀)**  
Description: Auxiliary Knife For Heavy Material  
代码/Part NO: 14119005  
适配: A5-W/A5E-W/A6F(-H)  
Machine Type: A5-W/A5E-W/A6F(-H)



名称: **活动刀**  
Description: Movable Knife  
代码/Part NO: 14119001  
适配: A5-W/A5E-W/A6F/A8<sup>+</sup>/A10<sup>+</sup>  
Machine Type: A5-W/A5E-W/A6F/A8<sup>+</sup>/A10<sup>+</sup>



名称: **定刀**  
Description: Fixed Knife  
代码/Part NO: 115019001  
适配: A2/A3/A4/A4E/A5E系列  
Machine Type: A2/A3/A4/A4E/A5E series



名称: **活动刀(薄料长槽)**  
Description: Movable Knife (H)  
代码/Part NO: 11319002  
适配: A2/A3/A4/A2S/5559G系列  
Machine Type: A2/A3/A4/A2S/5559G series



名称: **活动刀(厚料长槽)**  
Description: Movable Knife (H)  
代码/Part NO: 11319003  
适配: A2/A3/A4(A4E-H)系列  
Machine Type: A2/A3/A4 (A4E-H) series



名称: **活动刀(薄料短槽)**  
Description: Movable Knife  
代码/Part NO: 14019004  
适配: A4S/A5/A3E/A4E/A5E系列  
Machine Type: A4S/A5/A3E/A4E/A5E series



名称: **定刀**  
Description: Fixed Knife  
代码/Part NO: 13119001  
适配: A6F/80A/90C/100A系列  
Machine Type: A6F/80A/90C/100A series



名称: **动刀**  
Description: Movable Knife  
代码/Part NO: 13119004  
适配: A6F-HL/80A/90C/100A系列  
Machine Type: A6F-HL/80A/90C/100A series



## 厚料/双针动定刀 Heavy Duty/Double Needle Knife



名称: **定刀**  
Description: Fixed Knife  
代码/Part NO: 12319001  
适配: JK-58420J系列  
Machine Type: JK-58420J series



名称: **动刀**  
Description: Movable Knife  
代码/Part NO: 112319002  
适配: JK-58420J系列  
Machine Type: JK-58420J series



名称: **定刀**  
Description: Fixed Knife  
代码/Part NO: 13619001  
适配: JK-6380/6390/H5/  
H6/2002G/2030G  
Machine Type: JK-6380/6390/  
H5/H6/2002G/2030G



名称: **动刀**  
Description: Movable Knife  
代码/Part NO: 13619002  
适配: JK-6380/6390/H5/  
H6/2002G/2030G  
Machine Type: JK-6380/6390/  
H5/H6/2002G/2030G



名称: **定刀**  
Description: Fixed Knife  
代码/Part NO: 155219001  
适配: 6691/S5  
Machine Type: 6691/S5



名称: **动刀**  
Description: Movable Knife  
代码/Part NO: 155219002  
适配: 6691/S5  
Machine Type: 6691/S5



名称: **定刀**  
Description: Fixed Knife  
代码/Part NO: 155419001  
适配: 6691/S5  
Machine Type: 6691/S5

## 分线片 Needle Protect Patch



名称: **护针片**  
Description: Needle Protect Patch  
代码/Part NO: 11312003  
适配: A2/A3/A4/A4E/A5E  
Machine Type: A2/A3/A4/A4E/A5E



名称: **分线片**  
Description: Needle Protect Patch  
代码/Part NO: 14112001  
适配: A5/A6F/A6\*/A8\*/A10\*  
Machine Type: A5/A6F/A6\*/A8\*/A10\*

## A5-N压脚刀片 Knife For A5-N Presser Foot



名称: **刀片**  
Description: Knife  
代码/Part NO: 14019001  
适配: A5-N  
Machine Type: A5-N



名称: **刀片(进口)**  
Description: Knife  
代码/Part NO: 14119008  
适配: A5-N  
Machine Type: A5-N



名称: **直刀**  
Description: Knife  
代码/Part NO: 14019002  
适配: A5-N  
Machine Type: A5-N

## 特种机刀类 Special Machine Knife



名称: **剪底线动刀**  
Description: Movable Knife  
代码/Part NO: 803925  
适配: JK-T781系列  
Machine Type: JK-T781 series



名称: **剪底线定刀**  
Description: Fixed Knife  
代码/Part NO: 803927  
适配: JK-T781系列  
Machine Type: JK-T781 series



名称: **面线剪刀组件**  
Description: Needle Thread Trimmer Assembly  
代码/Part NO: 4021900100  
适配: JK-T781系列  
Machine Type: JK-T781 series



名称: **上剪线刀组件**  
Description: Upper Trimmer Assy  
代码/Part NO: 4131900200  
适配: JK-T1790系列  
Machine Type: JK-T1790 series



名称: **下剪线刀组件**  
Description: Lower Trimmer Assy  
代码/Part NO: 4131900300  
适配: JK-T1790系列  
Machine Type: JK-T1790 series

## 包缝动定刀 Overlock & Interlock Knife



名称: **反向定刀**  
Description: Fixed Knife  
代码/Part NO: 21119007  
适配: C5/C5+/C5SW/C6  
Machine Type: C5/C5+/C5SW/C6



名称: **上刀**  
Description: Upper Knife  
代码/Part NO: 30119001  
适配: 8670UT/K5S  
Machine Type: 8670UT/K5S



名称: **线辫割刀**  
Description: Knife  
代码/Part NO: 30119020  
适配: 8670B/C3/E4/E4S/K4-D/K5-D  
Machine Type: 8670B/C3/E4/E4S/K4-D/K5-D



名称: **定刀**  
Description: Fixed Knife  
代码/Part NO: 811116  
适配: C5/C5S/C8-KS  
Machine Type: C5/C5S/C8-KS



名称: **动刀**  
Description: Movable Knife  
代码/Part NO: 811117  
适配: C5-KS  
Machine Type: C5-KS



名称: **自动剪线定刀**  
Description: Fixed Knife  
代码/Part NO: 20719004  
适配: 798E/900E/799S/C3/C4  
Machine Type: 798E/900E/799S/C3/C4



名称: **动刀**  
Description: Movable Knife  
代码/Part NO: 30119016  
适配: 8569E/W4-UT  
Machine Type: 8569E/W4-UT



名称: **动刀**  
Description: Movable Knife  
代码/Part NO: 30119006  
适配: 8670UT/K5S  
Machine Type: 8670UT/K5S



名称: **上刀**  
Description: Upper Knife  
代码/Part NO: 30219001  
适配: 35AC系列  
Machine Type: 35AC Series



名称: **自动剪线动刀**  
Description: Movable Knife  
代码/Part NO: 20719003  
适配: C3/C4/C5/C5S/C5F/C6  
Machine Type: C3/C4/C5/C5S/C5F/C6

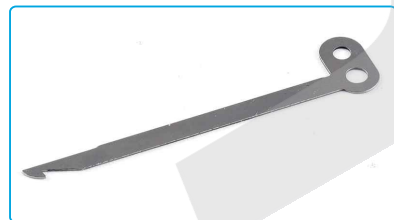

名称: **动刀**  
Description: Movable Knife  
代码/Part NO: 30119008  
适配: 8569E/W4-UT/W5-E  
Machine Type: 8569E/W4-UT/W5-E



名称: **切刀**  
Description: Knife  
代码/Part NO: 30119009  
适配: 8569E/W4-UT/W5-E  
Machine Type: 8569E/W4-UT/W5-E



名称: **下刀**  
Description: Lower Knife  
代码/Part NO: 30219002  
适配: 35AC系列  
Machine Type: 35AC Series



名称: **动刀**  
Description: Movable Knife  
代码/Part NO: 30219008  
适配: JK-8669-UT/W4-UT  
Machine Type: JK-8669-UT/W4-UT



名称: **定刀**  
Description: Fixed Knife  
代码/Part NO: 30219009  
适配: JK-8669-UT/W4-UT  
Machine Type: JK-8669-UT/W4-UT



刀片  
Knife

- ◎ 钨钢镶嵌
- ◎ 刀口锋利
- ◎ 经久耐磨

Tungsten Steel Inlay  
Sharp Edge  
Durable Wear Resistant



包缝上刀 Overlock Upper Knife



名称: 上刀  
Description: Upper Knife  
代码/Part NO: 20719050  
适配: 797/798T/C3/C4/E4/C5/C5S/C5F/C6系列所有A04/435机型  
Machine Type: A04/435 type for 797/798T/C3/C4/E4/C5/C5S/C5F/C6 Overlock series



名称: 上刀  
Description: Upper Knife  
代码/Part NO: 20719007  
适配: 797/798T/C3/C4/E4/C5系列 (不包含厚料和无纺织机型)  
Machine Type: 797/798T/C3/C4/E4/C5 Overlock series (Excluding heavy duty and non-woven fabric models)



名称: 上刀  
Description: Upper Knife  
代码/Part NO: 20119001  
适配: E3系列  
Machine Type: E3 series



名称: 上刀(厚料)  
Description: Upper Knife (Heavy Duty)  
代码/Part NO: 20119005  
适配: 805×2-56 E3-5×2-56  
Machine Type: 805×2-56 E3-5×2-56

包缝下刀 Overlock Lower Knife



名称: 下刀  
Description: Lower Knife  
代码/Part NO: 20119002  
适配: 包缝797/798T/E3/E4/C3/C4/C5系列机型 (除厚料和无纺织)  
Machine Type: 797/798T/E3/E4/C3/C4/C5 Overlock series (Except heavy material and non-woven fabric models)

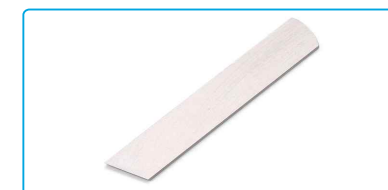

名称: 下刀  
Description: Lower Knife  
代码/Part NO: 20701053  
适配: 包缝E4/C4/C5/C3/797/798T系列所有厚料机型  
Machine Type: E4/C4/C5/C3/797/798T overlock series heavy duty models



名称: 下刀  
Description: Lower Knife  
代码/Part NO: 20719005  
适配: C4WF/E4SWF/K5-UT  
Machine Type: C4WF/E4SWF/K5-UT

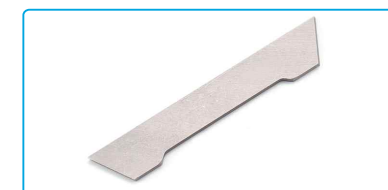

名称: 下刀(厚料)  
Description: Lower Knife (Heavy Duty)  
代码/Part NO: 20119006  
适配: E3-5×2-56  
Machine Type: E3-5×2-56



名称: 下刀  
Description: Lower Knife  
代码/Part NO: 21317002  
适配: 798/900E/E4/E4S/C5/C6  
Machine Type: 798/900E/E4/E4S/C5/C6



# 弯针 Looper

- ◎ 抛光处理，光滑无毛刺
- ◎ 特殊工艺，硬度高，耐磨不易断裂

Polishing processing, smooth without burr  
Special process, high hardness, wear resistance not easy to break



## 包缝上弯针 Overlock Upper Loper



名称: 上弯针  
Description: Upper Loper  
代码/Part NO: 20717004  
适配: 798T/E4/E4S/C3/C4/C5系列  
(除H/M和A04/435机型)  
Machine Type: 798T/E4/E4S/C3/C4/C5 series (Except H/M/A04/435 model)



名称: 上弯针  
Description: Upper Loper  
代码/Part NO: 20117025  
适配: E3系列3线和5线机型  
Machine Type: E3 series,  
3 thread & 5 thread model

名称: 上弯针  
Description: Upper Loper  
代码/Part NO: 20717050  
适配: 798T/E4/E4S/C3/C4/  
C5/C5S/C6系列H/M和A04/  
435机型  
Machine Type: H/M/A04/435 type for  
E4/C3/C4/C5/798T/E4S/C5S/C6 series



名称: 上弯针  
Description: Upper Loper  
代码/Part NO: 20117007  
适配: E3-4线系列  
Machine Type: E3-4 series

## 包缝下弯针 Overlock Lower Loper



名称: 下弯针  
Description: Lower Loper  
代码/Part NO: 20117008  
适配: E3 3/4线  
Machine Type: E3 series, 3  
thread & 4 thread model



名称: 下弯针  
Description: Lower Loper  
代码/Part NO: 20117009  
适配: E3 5线  
Machine Type: E3 series,  
5thread model



名称: 下弯针  
Description: Lower Loper  
代码/Part NO: 20717005  
适配: 798T/E4/C3/C4/C5  
系列M03/333机型  
Machine Type: M03/333 type  
for 798T/E4/C3/C4/C5 series

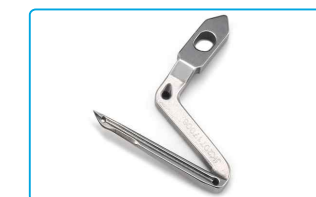

名称: 下弯针  
Description: Lower Loper  
代码/Part NO: 20717006  
适配: 798T/E4/C3/C4/C5  
系列(除M03/333机型)外的机型  
Machine Type: 798T/E4/C3/C4/C5  
series, (Except M03/333 model)

## 包缝链线弯针 Overlock Chain Loper



名称: 弯针  
Description: Loper  
代码/Part NO: 20712047  
适配: 798T/E4/C3/C4/C5  
系列(除A04/435)外的机型  
Machine Type: 798T/E4/C3/C4/C5  
series,(Except A04/435 model)



名称: 链线弯针  
Description: Chain Loper  
代码/Part NO: 20717051  
适配: 798T/E4/C3/C4/C5  
系列A04/435机型  
Machine Type: A04/435 type  
for 798T/E4/C3/C4/C5 series

## 绷缝弯针 Interlock Loper



名称: 弯针  
Description: Loper  
代码/Part NO: 30217003  
适配: 8670/K4/K5系列  
Machine Type: 8670/K4/K5  
series



名称: 弯针组  
Description: Loper  
代码/Part NO: 3011700900  
适配: W4/W4S系列  
Machine Type: W4/W4S series



针夹头  
Needle Clamp

◎ 专机定制 缝纫性能强

Customized special machine, excellent sewing performance



包缝针夹头 Overlock Needle Clamp



名称: 针夹头(三线)

Description: Needle Clamp (3 Thread)

代码/Part NO: 20734001

适配: 包缝所有3线和2线机型

Machine Type: 2 thread & 3 thread overlock series



名称: 针夹头(四线)

Description: Needle Clamp (4 Thread)

代码/Part NO: 20734002

适配: 包缝所有4线机型和无纺织物机型

Machine Type: 4 thread and non-woven fabric overlock series



名称: 针夹头(五线)

Description: Needle Clamp (5 Thread)

代码/Part NO: 20734003

适配: 798TD/798TE/E4/E4S/C3/C4/C5/C5S/C5F/C6/C8系列

Machine Type: 798TD/798TE/E4/E4S/C3/C4/C5/C5S/C5F/C6/C8 series



名称: 针夹头(五线70款)

Description: Needle Clamp (5 Thread 70 Type)

代码/Part NO: 20734004

适配: 798TD/798TE/E4/E4S/C3/C4/C5/C5S/C5F/C6/C8系列

Machine Type: 798TD/798TE/E4/E4S/C3/C4/C5/C5S/C5F/C6/C8 series



名称: 针夹头(五线厚料)

Description: Needle Clamp (5 Thread Heavy Duty)

代码/Part NO: 20719056

适配: 798TD/798TE/E4/E4S/C3/C4/C5/C5S/C5F/C6/C8系列

Machine Type: 798TD/798TE/E4/E4S/C3/C4/C5/C5S/C5F/C6/C8 series

绷缝针夹头 Interlock Needle Clamp



名称: 针夹头(356)

Description: Needle Clamp (356)

代码/Part NO: 30134001

适配: 8670/W4/W4S/K4/K5/K6系列

Machine Type: 8670/W4/W4S/K4/K5/K6 all series



名称: 针夹头(364)

Description: Needle Clamp (364)

代码/Part NO: 30134002

适配: 8670/W4/W4S/K4/K5系列

Machine Type: 8670/W4/W4S/K4/K5 all series



# 针杆

Needle Bar

- 精密加工, 表面光滑
- DLC处理, 硬度高, 耐磨使用寿命长
- 独立包装, 不易生锈

Precise processing, smooth surface.  
DLC processing, high hardness, long service life.  
Individual package, not easy to rust.



◎ 原厂原装, 品质保障  
Original quality, quality assurance

## 平缝/厚料机针杆 Lockstitch/Heavy Duty Machine Needle Bar



名称: 针杆  
Description: Needle Bar  
代码/Part NO: 10102021  
适配: 平缝系列厚料用  
Machine Type: Lockstith series

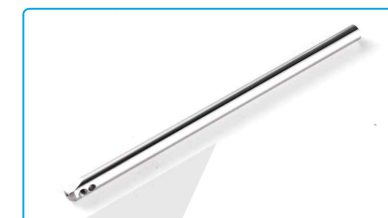

名称: 针杆  
Description: Needle Bar  
代码/Part NO: 10102002  
适配: 普通平车通用  
Machine Type: Ordinary lockstitch series



名称: 针杆  
Description: Needle Bar  
代码/Part NO: 11402039  
适配: 电脑平车通用  
Machine Type: Computer lockstitch series



名称: 针杆(DLC)  
Description: Needle Bar (After DLC)  
代码/Part NO: 11402034  
适配: A5-W/A5E-W/A6+/A8+/A10+  
Machine Type: A5-W/A5E-W/A6+/A8+/A10+



名称: 针杆(DLC)  
Description: Needle Bar (After DLC)  
代码/Part NO: 14402012  
适配: A6F  
Machine Type: A6F



名称: 针杆  
Description: Needle Bar  
代码/Part NO: 10102012  
适配: JK-609S/8720H  
Machine Type: JK-609S/8720H



名称: 针杆  
Description: Needle Bar  
代码/Part NO: 13602002  
适配: 6380/H2/H5/H6/2002G  
Machine Type: 6380/H2/H5/H6/2002G



## 包缝针杆 Overlock Needle Bar



名称: **针杆组件**  
Description: Needle Bar  
代码/Part NO: 2010220700  
适配: E3系列  
Machine Type: E3 series



名称: **针杆组件**  
Description: Needle Bar  
代码/Part NO: 2080201800  
适配: JK-798T系列  
Machine Type: JK-798T series



名称: **针杆组件**  
Description: Needle Bar  
代码/Part NO: 2060303100  
适配: 798/800系列  
Machine Type: 798/800 series



名称: **针杆组件**  
Description: Needle Bar  
代码/Part NO: 2120200100  
适配: E4/E4S/C3  
Machine Type: E4/E4S/C3



名称: **针杆组件**  
Description: Needle Bar  
代码/Part NO: 2110200900  
适配: C4/C5/C6/C5F  
Machine Type: C4/C5/C6/C5F

## 特种机针杆 Special Machine Needle Bar



名称: **针杆(DLC)**  
Description: Needle Bar (DLC)  
代码/Part NO: 40202057  
适配: JK-T781系列  
Machine Type: JK-T781 series



名称: **针杆(DLC)**  
Description: Needle Bar (DLC)  
代码/Part NO: 41302007  
适配: JK-T1790系列  
Machine Type: JK-T1790 series



名称: **针杆(DLC)**  
Description: Needle Bar (DLC)  
代码/Part NO: 40302015  
适配: JK-T1900系列  
Machine Type: JK-T1900 series



名称: **针杆**  
Description: Needle Bar  
代码/Part NO: 40902027  
适配: JK-T1377E/373E  
Machine Type: JK-T1377E/373E



名称: **针杆**  
Description: Needle Bar  
代码/Part NO: 13602002  
适配: 6380/H2/H5/H6/2002G  
Machine Type: 6380/H2/H5/H6/2002G



## 双针机针位

Needle Gauge For Double Needle Machine

- ◎ 精雕细琢 送料稳妥
- ◎ 精细化加工, 平滑无毛刺, 送料平稳

Precise processing, Feeding smoothly  
Smooth Surface, Stable Fabric Feeding

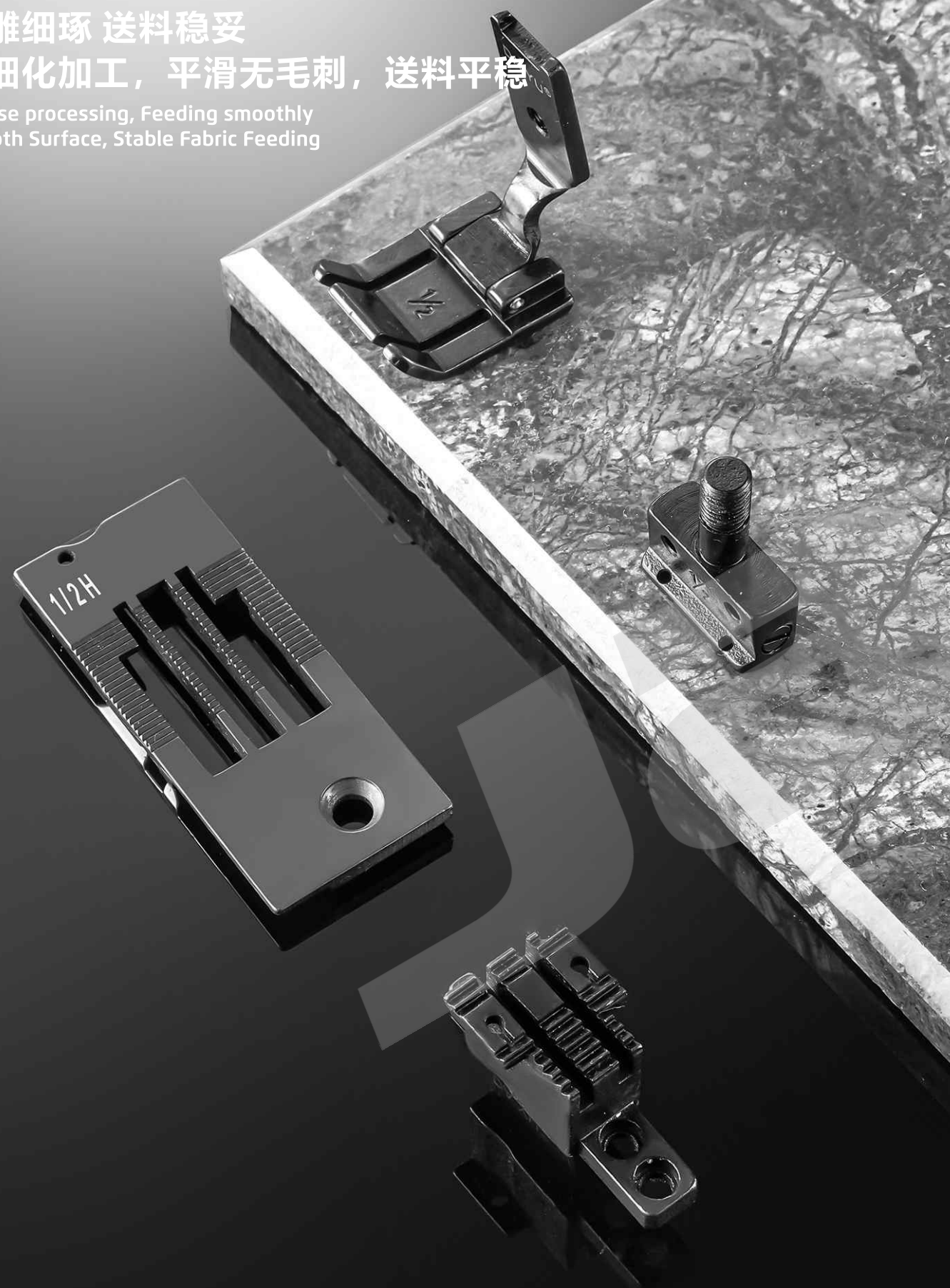

名称: **针位(1/8)**  
Description: Needle Gauge 1/8  
代码/Part NO: 810586+12915306  
适配: JK-58420G/J 58720G/J  
Machine Type: JK-58420G/J 58720G/J

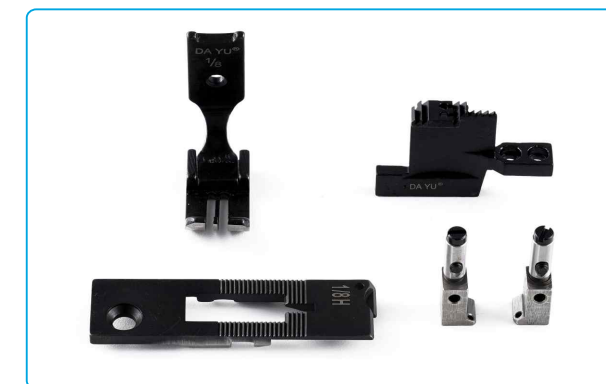

名称: **针位(1/8)**  
Description: Needle Gauge 1/8  
代码/Part NO: 810590+12915306  
适配: JK-58450G/J 58750G/J  
Machine Type: JK-58450G/J 58750G/J

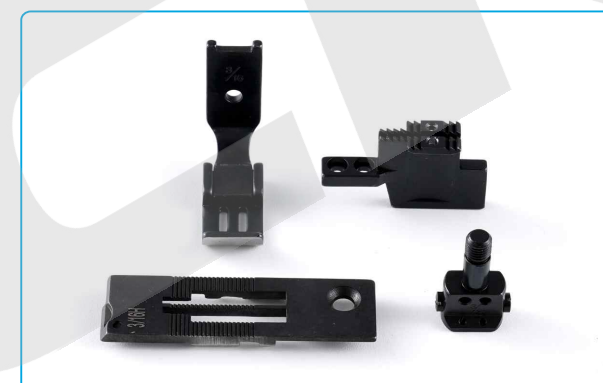

名称: **针位(3/16)**  
Description: Needle Gauge 3/16  
代码/Part NO: 810756+12915307  
适配: JK-58420G/J 58720G/J  
Machine Type: JK-58420G 58720G/J



名称: **针位(3/16)**  
Description: Needle Gauge 3/16  
代码/Part NO: 810761+12915307  
适配: JK-58450G/J 58750G/J  
Machine Type: JK-58450G/J 58750G/J

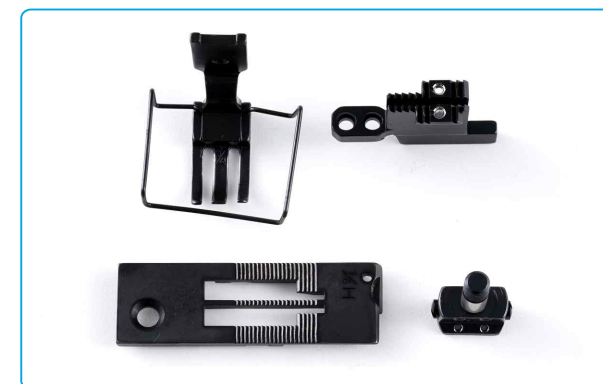

名称: **针位1/4(-3)**  
Description: 58420D Needle Gauge 1/4 (-3)  
代码/Part NO: 12915206+11634001+12914301  
+1291632500  
适配: JK-58420G/J-403 58720G/J-403  
Machine Type: JK-58420G/J-403 58720G/J-403

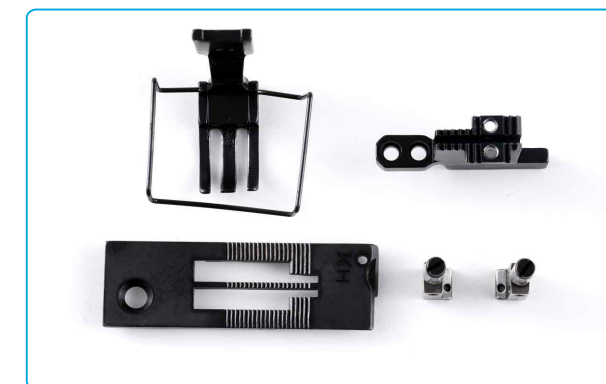

名称: **送布牙1/4(-5)**  
Description: Needle Gauge 1/4 (-5)  
代码/Part NO: 11734003+11734002+12914314  
+12915206+1291632500  
适配: JK-58450G/J-405 58750G/J-405  
Machine Type: JK-58450G/J-405 58750G/J-405



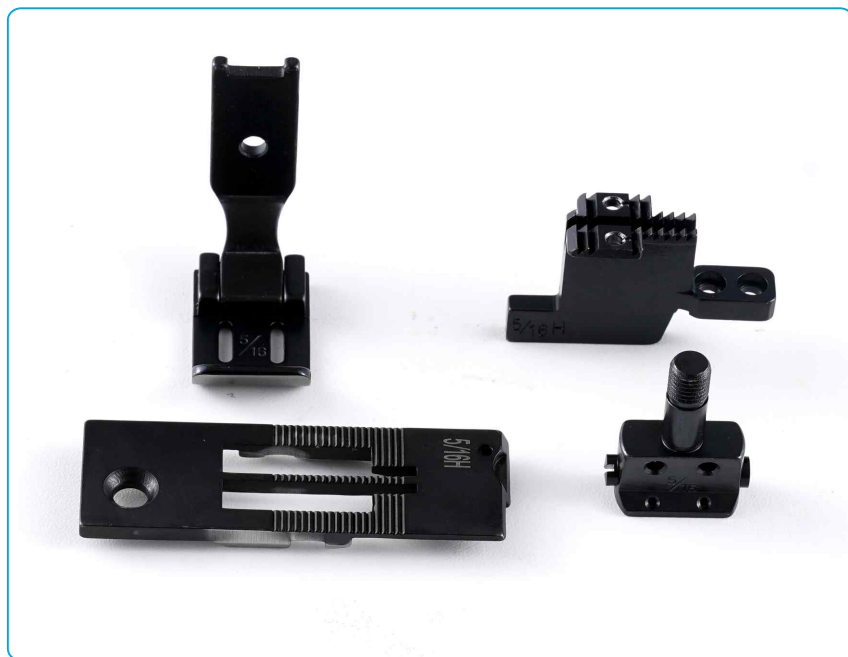

名称: **针位(5/16)**  
Description: Needle Gauge 5/16  
代码/Part NO: 804008+12915309  
适配: JK-58420G/J 58720G/J  
Machine Type: JK-58420G/J 58720G/J



名称: **针位(5/8)**  
Description: Needle Gauge 5/8  
代码/Part NO: 810593+12915314  
适配: JK-58450G/J 58750G/J  
Machine Type: JK-58450G/J 58750G/J



名称: **针位(3/4)**  
Description: Needle Gauge 3/4  
代码/Part NO: 811002+12915315  
适配: JK-58420G/J 58720G/J  
Machine Type: JK-58420G/J 58720G/J



名称: **针位(5/16)**  
Description: Needle Gauge (5/16)  
代码/Part NO: 810800+12915309  
适配: JK-58450G/J 58750G/J  
Machine Type: JK-58450G/J 58750G/J

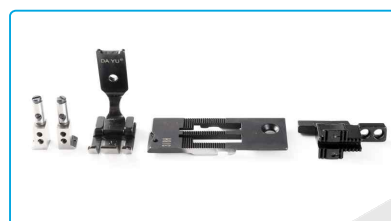

名称: **针位(3/8)**  
Description: Needle Gauge 3/8  
代码/Part NO: 810591+12915308  
适配: JK-58450G/J 58750G/J  
Machine Type: JK-58450G/J 58750G/J

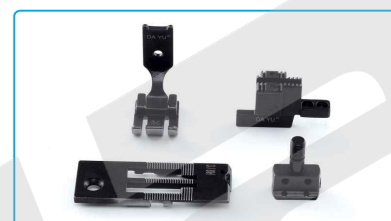

名称: **针位(3/8)**  
Description: Needle Gauge 3/8  
代码/Part NO: 810587+12915308  
适配: JK-58420G/J 58720G/J  
Machine Type: JK-58420G/J 58720G/J



名称: **针位(3/4)**  
Description: Needle Gauge 3/4  
代码/Part NO: 811005+12915315  
适配: JK-58450G/J 58750G/J  
Machine Type: JK-58450G/J 58750G/J



名称: **针位(7/8)**  
Description: Needle Gauge 7/8  
代码/Part NO: 811003+12915316  
适配: JK-58420G/J 58720G/J  
Machine Type: JK-58420G/J 58720G/J



名称: **针位(1/2)**  
Description: Needle Gauge 1/2  
代码/Part NO: 810588+12915312  
适配: JK-58420G/J 58720G/J  
Machine Type: JK-58420G/J 58720G/J



名称: **针位(1/2)**  
Description: Needle Gauge 1/2  
代码/Part NO: 810592+12915312  
适配: JK-58450G/J 58750G/J  
Machine Type: JK-58450G/J 58750G/J



名称: **针位(5/8)**  
Description: Needle Gauge 5/8  
代码/Part NO: 810589+12915314  
适配: JK-58420G/J 58720G/J  
Machine Type: JK-58420G/J 58720G/J



名称: **针位(7/8)**  
Description: Needle Gauge 7/8  
代码/Part NO: 811006+12915316  
适配: JK-58450G/J 58750G/J  
Machine Type: JK-58450G/J 58750G/J

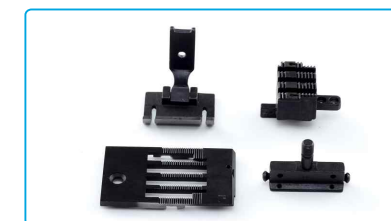

名称: **针位(1)**  
Description: Needle Gauge 1  
代码/Part NO: 811004+12915317  
适配: JK-58420G/J 58720G/J  
Machine Type: JK-58420G/J 58720G/J



名称: **针位(1)**  
Description: Needle Gauge 1  
代码/Part NO: 811007+12915317  
适配: 58450G/J 58750G/J  
Machine Type: 58450G/J 58750G/J



**夹线器**  
Thread Tension

- ◎ 质量把控, 层层筛选
- ◎ 杰克原厂, 品质保障
- ◎ 不卡线, 不断线, 高品质夹线器

Quality control, layers of screening  
JACK original, quality assurance  
No thread sticking, no thread breaking, high quality thread tension



**平缝夹线器** Lockstitch Thread Tension



名称: **夹线器组件**  
Description: Thread Tension Asm.  
代码/Part NO: 1411300300  
适配: 电脑平车通用  
Machine Type: Computerized lockstitch machine



名称: **小夹线器组件**  
Description: Thread Tension Asm  
代码/Part NO: 1411300400  
适配: 电脑平车通用  
Machine Type: Computerized lockstitch machine



名称: **底线夹线器**  
Description: Bobbin Thread Tension Asm  
代码/Part NO: 1411300600  
适配: 电脑平车通用  
Machine Type: Computerized lockstitch machine



名称: **夹线器组件(厚料)**  
Description: Thread Tension Asm (H)  
代码/Part NO: 1411300500  
适配: 电脑平车通用 (-H机型)  
Machine Type: Computerized lockstitch machine (-H series)



名称: **电子夹线器组件**  
Description: Electric Thread Tension Asm  
代码/Part NO: 1383002700  
适配: 电脑平车通用  
Machine Type: Computerized lockstitch machine



名称: **底线夹线器**  
Description: Thread Tension Asm  
代码/Part NO: 1381300600  
适配: F3/F4/A2/A2S/5558G/A3-B  
Machine Type: F3/F4/A2/A2S/5558G/A3-B



名称: **小夹线器组件**  
Description: Thread Tension Asm  
代码/Part NO: 1381300400  
适配: A2/A2S/A3-B  
Machine Type: A2/A2S/A3-B





名称: **夹线器组件**  
Description: Thread Tension Asm  
代码/Part NO: 1381300700  
适配: F4/A2/A2S  
Machine Type: F4/A2/A2S



名称: **夹线器组件**  
Description: Thread Tension Asm.  
代码/Part NO: 11381301500  
适配: R3/R5/R4E/R4000/R5E/R6  
Machine Type: R3/R5/R4E/R4000/R5E/R6

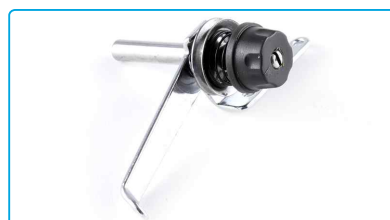

名称: **小夹线器组件**  
Description: Thread Tension Asm  
代码/Part NO: 1381300100  
适配: R2/R3/R4E/R4000  
Machine Type: R2/R3/R4E/R4000



名称: **小夹线器组件**  
Description: Thread Tension Asm.  
代码/Part NO: 11381301400  
适配: R5/R5E/R6/R5000/R6000  
Machine Type: R5/R5E/R6/R5000/R6000



名称: **夹线器组件**  
Description: Thread Tension Asm  
代码/Part NO: 1381300900  
适配: R2/Q5  
Machine Type: R2/Q5



名称: **底线夹线器**  
Description: Thread Tension Asm  
代码/Part NO: 1381300200  
适配: R2/R3/R4E/R5/Q5/R4000  
Machine Type: R2/R3/R4E/R5/Q5/R4000



名称: **夹线器组件**  
Description: Thread Tension Asm.  
代码/Part NO: 11471300100  
适配: H2/H5/H6/63809/6390  
Machine Type: H2/H5/H6/63809/6390



名称: **少鸟巢电子夹线器**  
Description: Electric Thread Tension Asm  
代码/Part NO: 1363001000  
适配: H5/H6/6380/6390  
Machine Type: H5/H6/6380/6390

## 包缝缝夹线器 Overlock And Interlock Thread Tension



名称: **夹线器组件(红点)**  
Description: Thread Tension Asm (Red)  
代码/Part NO: 2111300500  
适配: E4/E4S/C3/C4/C5/C5S  
Machine Type: E4/E4S/C3/C4/C5/C5S



名称: **夹线器组件(蓝点)**  
Description: Thread Tension Asm (Blue)  
代码/Part NO: 2111300600  
适配: E4/E4S/C3/C4/C5/C5S  
Machine Type: E4/E4S/C3/C4/C5/C5S



名称: **夹线器组件(绿点)**  
Description: Thread Tension Asm (Green)  
代码/Part NO: 2111300700  
适配: E4/E4S/C3/C4/C5/C5S  
Machine Type: E4/E4S/C3/C4/C5/C5S



名称: **夹线器组件(黄点)**  
Description: Thread Tension Asm (Yellow)  
代码/Part NO: 2111300800  
适配: E4/E4S/C3/C4/C5/C5S  
Machine Type: E4/E4S/C3/C4/C5/C5S



名称: **夹线器组件**  
Description: K4 Thread Tension Asm  
代码/Part NO: 3101300800  
适配: W4/K4/K5/K5E  
Machine Type: W4/K4/K5/K5E

## 特种机夹线器 Special Machine Thread Tension



名称: **电子夹线器组件**  
Description: Electric Thread Tension of 1790  
代码/Part NO: 4131301900  
适配: JK-T1790系列  
Machine Type: JK-T1790 Series



名称: **主夹线器组件**  
Description: Thread Tension of 2210  
代码/Part NO: 4171302000  
适配: JK-T1310/T2210/T3020  
Machine Type: JK-T1310/T2210/T3020



**绕线器**  
Bobbin Winder

◎ 绕线顺畅，品质保障

◎ 自动绕线割线一体，无需手动绕线，省时省力

Smooth winding, quality assurance

Automatic winding and cutting integrated, No manual winding, save time and labor



**平缝绕线器** Lockstitch Bobbin Winder



名称: **绕线器组件**  
Description: Bobbin Winder  
代码/Part NO: 1383103900  
适配: F4/A2/A2S/A3/A4/A3E/A4E/5558G  
Machine Type: F4/A2/A2S/A3/A4/A3E/A4E/5558G



名称: **绕线器组件**  
Description: Bobbin Winder  
代码/Part NO: 1413104900  
适配: A5/A5E/A6+  
Machine Type: A5/A5E/A6+



名称: **绕线器组件**  
Description: Bobbin Winder  
代码/Part NO: 1013109600  
适配: 9100B系列  
Machine Type: 9100B series



名称: **绕线器组件**  
Description: Bobbin Winder  
代码/Part NO: 1383103600  
适配: R3/Q5/R4E/R4000  
Machine Type: R3/Q5/R4E/R4000



名称: **绕线器组件**  
Description: Bobbin Winder  
代码/Part NO: 11383100400  
适配: R5/R5E/R6/R5000  
Machine Type: R5/R5E/R6/R5000

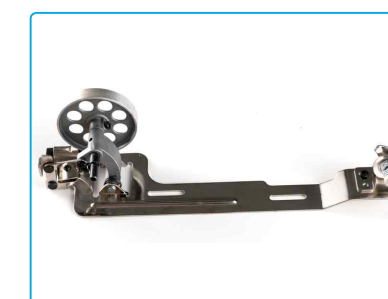

名称: **绕线器组件**  
Description: Bobbin Winder  
代码/Part NO: 1013100600  
适配: JK-8720  
Machine Type: JK-8720



## 双针/厚料绕线器 Double Needle/Heavy Duty Bobbin Winder



名称: **绕线器组件**  
Description: Bobbin Winder  
代码/Part NO: 1233100400  
适配: 双针系列通用  
Machine Type: Double needle series

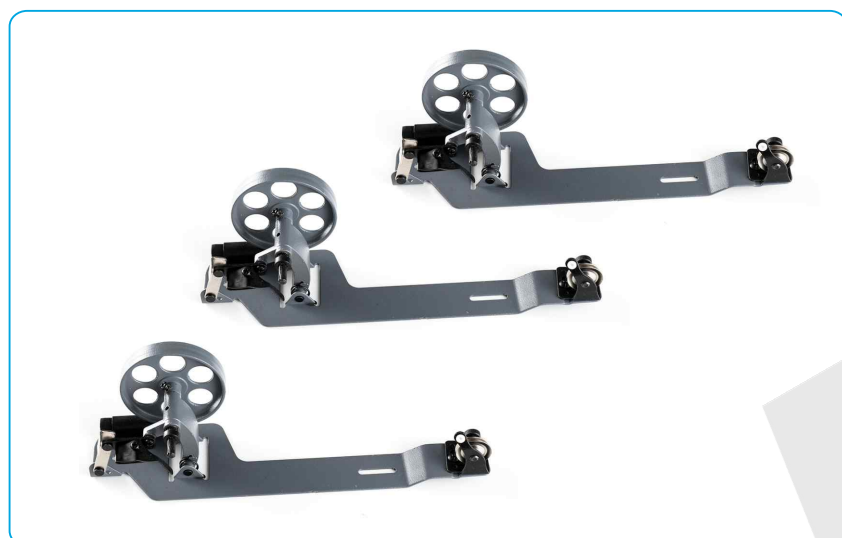

名称: **绕线器组件**  
Description: Bobbin Winder  
代码/Part NO: 1163101600  
适配: JK-609S  
Machine Type: JK-609S



名称: **绕线器组件**  
Description: Bobbin Winder  
代码/Part NO: 1363102000  
适配: JK-6380  
Machine Type: JK-6380



名称: **绕线器组件**  
Description: Bobbin Winder  
代码/Part NO: 1363102100  
适配: JK-6380  
Machine Type: JK-6380



名称: **绕线器组件**  
Description: Bobbin Winder  
代码/Part NO: 1473100100  
适配: H2/H5/H6  
Machine Type: H2/H5/H6

## 特种机绕线器 Special Machine Bobbin Winder



名称: **绕线器组件**  
Description: Bobbin Winder  
代码/Part NO: 4033160900  
适配: JK-T1900系列  
Machine Type: JK-T1900 series



名称: **割绕一体绕线器**  
Description: Bobbin Winder  
代码/Part NO: 14133101800  
适配: JK-T1790系列  
Machine Type: JK-T1790 series



名称: **自动绕线器**  
Description: Auto Bobbin Winder  
代码/Part NO: 41831222  
适配: MS/MC-80B/80C/90A/90C/100A  
Machine Type: MS/MC-80B/80C/90A/90C/100A



名称: **绕线器组件**  
Description: Bobbin Winder  
代码/Part NO: 4023103000  
适配: JK-T781系列  
Machine Type: JK-T781 series



# 电磁铁 Solenoid

- ◎ 强吸引力 导线性能良好
- ◎ 温度稳定性与绝缘性
- ◎ 低碳钢外壳 剩磁少

strong suction power Good wire performance  
Temperature stability and insulation  
Carbon steel cover less remanence



## 平缝电磁铁 Lockstitch Solenoid



名称: 抬压脚电磁铁组件  
Description: Foot Lifting Solenoid  
代码/Part NO: 11383001300  
适配: A3-4/A4/A5/5559G  
Machine Type: A3-4/A4/A5/5559G



名称: 自动倒送料电磁铁  
Description: Reverse Feed Solenoid  
代码/Part NO: 1383003400  
适配: A2S/A3-4/A4/A5/5559G  
Machine Type: A2S/A3-4/A4/A5/5559G



名称: 剪线电磁铁组件  
Description: Trimmer Solenoid  
代码/Part NO: 1383003300  
适配: A2S/A3-4/A4/A5/5559G  
Machine Type: A2S/A3-4/A4/A5/5559G

## 包缝电磁铁 Overlock Solenoid



名称: 包缝AT剪线电磁铁组件  
Description: AT Trimmer Asm.  
代码/Part NO: 2073001300  
适配: 798TE  
Machine Type: 798TE



名称: 抬压脚电磁铁  
Description: Foot Lifting Solenoid  
代码/Part NO: 2073001700  
适配: 905E  
Machine Type: 905E



名称: 抬压脚电磁铁  
Description: Foot Lifting Solenoid  
代码/Part NO: 2113030900  
适配: C4/C4+/C4WF  
Machine Type: C4/C4+/C4WF



名称: 剪线电磁铁  
Description: Trimmer Solenoid  
代码/Part NO: 12114700300  
适配: C3/C4/C5  
Machine Type: C3/C4/C5

## 绷缝电磁铁 Interlock Solenoid



名称: 剪线电磁铁组件  
Description: Trimmer Solenoid  
代码/Part NO: 3103000700  
适配: W4-UT/K4-UT  
Machine Type: W4-UT/K4-UT



名称: 抬压脚电磁铁组件  
Description: Foot Lifting Solenoid  
代码/Part NO: 3103001100  
适配: W4-UT/K4-UT  
Machine Type: W4-UT/K4-UT



名称: 下切刀组件  
Description: Lower Knife Holder Assembly  
代码/Part No: 3101900100 + 31030005  
适配: 8569E/W4-UT/W5-E  
Machine Type: 8569E/W4-UT/W5-E

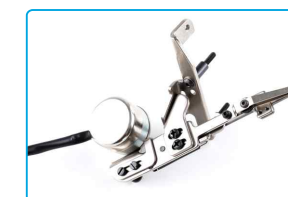

名称: 上切刀组件 + 电磁铁组件  
Description: Upper Knife Holder Assembly  
代码/Part No: 3013001600 + 3011900400  
适配: 8670UT/K5S  
Machine Type: 8670UT/K5S

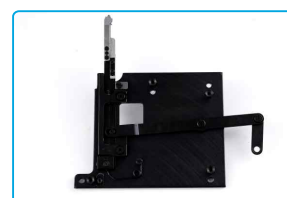

名称: 上切刀组件  
Description: Upper Knife Assembly  
代码/Part NO: 3101900100  
适配: W4-UT/W4E-UT/  
W5E-UT/K4-UT/K5-UT  
Machine Type: W4-UT/W4E-UT/  
W5E-UT/K4-UT/K5-UT

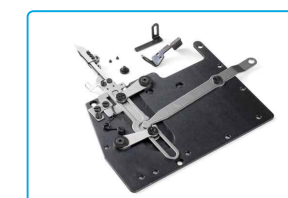

名称: 下切刀组件  
Description: Knife Holder Assembly  
代码/Part NO: 3121900100  
适配: JK-8669-UT/W4-UT  
Machine Type: JK-8669-UT/W4-UT



## 包缝连杆

Overlock Connecting Rod

- ◎ 依据机器性能选材 匹配度高
- ◎ 优选精品铜 高硬度散热快
- ◎ 轻便铝材 减轻负荷低震动

Material Option according to operating speed

High match with Machine

High-quality Copper with superior hardness, cool down fast

light aluminium, less load less vibration



## 包缝连杆 Overlock Connecting Rod



名称: **弯针连杆**  
Description: Looper Connecting Rod  
代码/Part NO: 121205002  
适配: 798D/E4/C3  
Machine Type: 798D/E4/C3



名称: **弯针连杆(铝)**  
Description: Looper Connecting Rod  
代码/Part NO: 400043  
适配: 90E/C4/C5  
Machine Type: 90E/C4/C5



名称: **上刀连杆**  
Description: Upper Knife Connecting Rod  
代码/Part NO: 121205004  
适配: 798D/E4/C3  
Machine Type: 798D/E4/C3



名称: **上刀连杆(铝)**  
Description: Upper Knife Connecting Rod  
代码/Part NO: 400041  
适配: 90E/C4/C5  
Machine Type: 90E/C4/C5

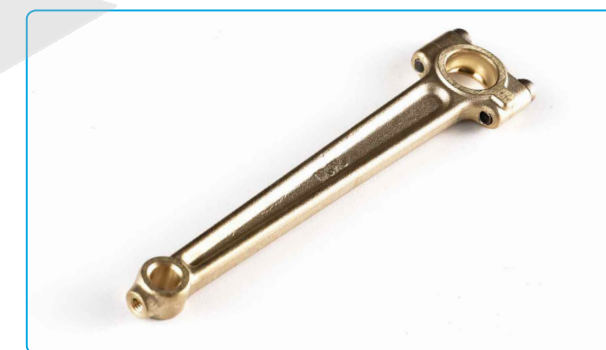

名称: **针杆连杆**  
Description: Needle Bar Connecting Rod  
代码/Part NO: 121205003  
适配: 798D/E4/C3  
Machine Type: 798D/E4/C3



名称: **针杆连杆(铝)**  
Description: Needle Bar Connecting Rod  
代码/Part NO: 400039  
适配: 900E/C4/C5S  
Machine Type: 900E/C4/C5S



名称: **针杆连杆**  
Description: Needle Bar Connecting Rod  
代码/Part NO: 21105011  
适配: C4/C5  
Machine Type: C4/C5



**剪线刀组**  
Thread Trimmer Asm

- ◎ 多样化剪线选择
- ◎ 优质钢材 刃口锋利 线头美观
- ◎ 耐磨使用寿命长

A variety option of thread trimming types  
Selected steel, sharp blade and short thread end  
Wear-resisting and durable



**剪线刀组 Thread Trimmer Asm**



名称: **吸风剪线刀组件**  
Description: Suction Trimmer Asm  
代码/Part NO: 2071208400  
适配: C5-5-M04/435/AT  
Machine Type: C5-5-M04/435/AT

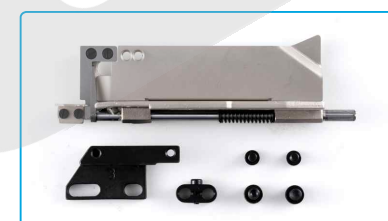

名称: **自动剪线组件**  
Description: No-Suction Trimmer Asm  
代码/Part NO: 2071208200  
适配: 900E/C3/C4  
Machine Type: 900E/C3/C4



名称: **剪线刀组件(吸风)**  
Description: Suction Trimmer Asm  
代码/Part NO: 12111201300  
适配: C5/C5+/C6-SD/X  
Machine Type: C5/C5+/C6-SD/X



名称: **剪线刀组件**  
Description: No-Suction Trimmer Asm  
代码/Part NO: 2111208200  
适配: C5/C5+/C5F/C6  
Machine Type: C5/C5+/C5F/C6



名称: **自动剪线刀组件**  
Description: Thread Trimmer Asm  
代码/Part NO: 2071208900  
适配: C4/C5-BK  
Machine Type: C4/C5-BK



名称: **KH组件(KH020D)**  
Description: KH Trimmer Asm  
代码/Part NO: 2071206100  
适配: C5/C5S/C8-KH  
Machine Type: C5/C5S/C8-KH



名称: **KS组件**  
Description: KS Trimmer Asm  
代码/Part NO: 2111204300  
适配: E4S/C4/C5/C5S-KS  
Machine Type: E4S/C4/C5/C5S-KS



# 双开关

LED And Switch

- ◎ 高灵敏度，不易损坏
- ◎ 按键耐用性高
- ◎ 操作方便 任意切换功能

High sensitivity and durable  
Long service life of key  
Convenient operation and arbitrary function switch



## 开关 LED And Switch



名称: **双开关组件**  
Description: LED And Switch  
代码/Part NO: 1383003700  
适配: A4-X  
Machine Type: A4-X



名称: **双开关组件**  
Description: LED And Switch  
代码/Part NO: 1403003600  
适配: A3-X/A4-X/A4S  
Machine Type: A3-X/A4-X/A4S



名称: **倒缝开关组件**  
Description: LED And Switch  
代码/Part NO: 1383004700  
适配: A2S/A3/A4/A5  
Machine Type: A2S/A3/A4/A5



名称: **双开关组件**  
Description: LED And Switch  
代码/Part NO: 1413003600  
适配: A5  
Machine Type: A5



名称: **倒缝开关组件(三开关)**  
Description: LED And Switch  
代码/Part NO: 11503002100  
适配: A5E  
Machine Type: A5E



名称: **LED灯开关组件**  
Description: LED And Switch  
代码/Part No: 1443000700+  
1443000400  
适配: A6X  
Machine Type: A6X



名称: **剪线开关组件**  
Description: Trimmer Switch  
代码/Part NO: 2121102600  
适配: C3  
Machine Type: C3



名称: **剪线开关组件**  
Description: Trimmer Switch  
代码/Part NO: 2111102600  
适配: C4  
Machine Type: C4



名称: **剪线开关组件**  
Description: Trimmer Switch  
代码/Part NO: 2111103200  
适配: C5  
Machine Type: C5

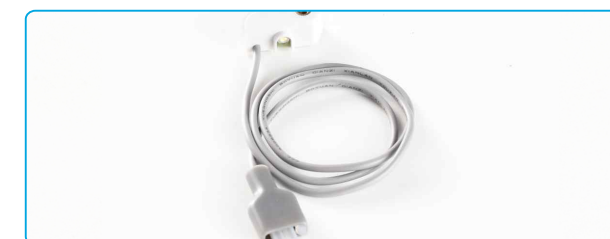

名称: **LED灯组件**  
Description: LED Light  
代码/Part NO: 2123000300  
适配: E4  
Machine Type: E4



## 上弯针滑杆

Upper Looper Holder Assy

- ◎ 电镀工艺 坚硬耐磨
- ◎ 发黑工艺, 高硬度, 耐磨损, 使用寿命更长

Electroplating technology, High hardness & wear-resisting  
DLC process, wear-resisting, long service life.

## 包缝上弯针滑杆 Overlock Upper Looper Holder Assy



名称: **上弯针滑杆组件**  
Description: Upper Looper Holder Assy  
代码/Part NO: 2070400500  
适配: E4/E4S/C3  
Machine Type: E4/E4S/C3



名称: **上弯针滑杆组件(DLC厚料)**  
Description: Upper Looper Holder Assy(DLC H)  
代码/Part NO: 2070404100  
适配: JK-798T系列  
Machine Type: JK-798T series



名称: **上弯针滑杆组件**  
Description: Upper Looper Holder Assy  
代码/Part NO: 2010121000  
适配: E3系列  
Machine Type: E3 series



名称: **上弯针滑杆组件(DLC)**  
Description: Upper Looper Holder Assy  
代码/Part NO: 2070403400  
适配: E4S/C4/C5/C6  
Machine Type: E4S/C4/C5/C6



名称: **上弯针滑杆组件(厚料)**  
Description: Upper Looper Holder Assy(H)  
代码/Part NO: 2070403600  
适配: E4/E4S/C3  
Machine Type: E4/E4S/C3



名称: **上弯针滑杆组件DLC厚料**  
Description: Upper Looper Holder Assy(H)  
代码/Part NO: 2070403500  
适配: C4/C5/C5S/C6  
Machine Type: C4/C5/C5S/C6



# 辅件类

— Accessories —

小零件 大学问

选零件

还是杰克原装好

Small parts, Big knowledge  
Jack original parts, Your first choice



## 杰克原厂 抗磨能力强 不易挥发

Jack original, Strong wear resistance, Not easy to volatilize

- 机器适配机油，原厂原装，机器更顺畅
  - 抗磨能力强、不易挥发
  - 匹配度高，机器跑合更顺畅
- Machine adapter oil, Jack original, smoother sewing.  
Strong wear resistance, not easy to volatilize.  
Higher match, machine running more smoothly.



### 白油

Machine Oil



名称: 10#白油(瓶装)  
Description: Machine Oil (10#)  
代码/Part NO: 811484  
适配: 平缝系列  
Machine Type: Lockstitch Series



名称: 白油10# (10L)  
Description: Machine Oil 10# (10L)  
代码/Part NO: 811193  
适配: 平缝系列  
Machine Type: Lockstitch Series



名称: 22#白油(瓶装)  
Description: Machine Oil (22#)  
代码/Part NO: 811485  
适配: 包缝系列  
Machine Type: Overlock series



名称: 包缝白油22# (10L)  
Description: Machine Oil 22# (10L)  
代码/Part NO: 811194  
适配: 包缝系列  
Machine Type: Overlock series





## U型手柄 尖头设计 防静电

U-handle, Tip design, Anti-static

- 加厚U型手柄一次成型设计硬度高、重量轻
  - 采用高碳工具钢，锐利刀锋、耐磨，能轻松应对连续几万次的高强度剪切
  - 圆形小孔可防止因静电及潮湿引起的布料及线头粘黏
- Thickened U-shaped handle with high hardness and light weight.  
With high carbon tool steel, sharp blade and wear resistance, it can easy cope with tens of thousands of continuous high strength shear.  
Circular orifice can prevent fabric and thread sticking caused by static electricity and humidity.



### 专利纱剪

Patent Yarn Scissors



名称: **专利纱剪**  
Description: Patent Yarn Scissors  
代 码/Part NO: 810735

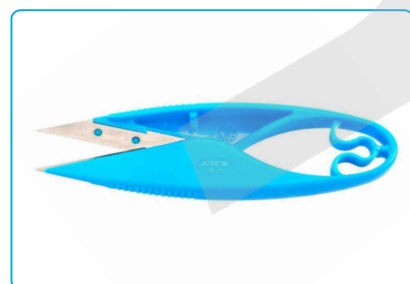

名称: **杰克双刃纱剪**  
Description: Double Edged Yarn Scissors  
代 码/Part NO: 811476



名称: **塑柄不锈钢纱剪**  
Description: Plastic-handle Thread Scissors  
代 码/Part NO: 800018



### 铁纱剪

Metal Scissors



名称: **铁纱剪(小号)**  
Description: Metal Scissors (S)  
代 码/Part NO: 810736



名称: **铁纱剪(大号)**  
Description: Metal Scissors (L)  
代 码/Part NO: 810737





## 抗磨性强 专利压槽 不偏布

Strong wear resistance, Patent groove, No fabric-pushing

- 一体成型，弧型手柄，更贴合人体工程学设计
- 长时间剪裁不会硌手
- 剪尖平头处理，不带头，不扎布；剪刀经过多道工序精磨抛光，刃面光泽自然
- 专利压槽，剪布不跑布，不偏布，精准度高

Cambered hand shank with integrated design.  
Humanization design.  
Shears with flat head processing, does not tie fabric, the scissor is polished by many processes, make the blade surface more shiny.  
Patent groove, no fabric pushing, high precision.



## 服装剪

Fabric Scissors

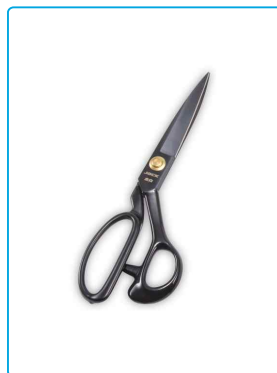

名称: **服装剪9寸**  
Description: Fabric Scissors 9"  
代码/Part NO: 810731

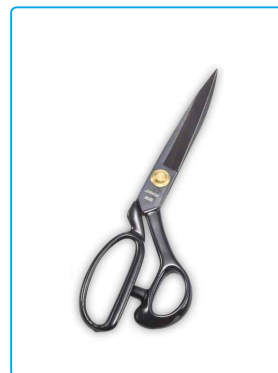

名称: **服装剪10寸**  
Description: Fabric Scissors 10"  
代码/Part NO: 810732

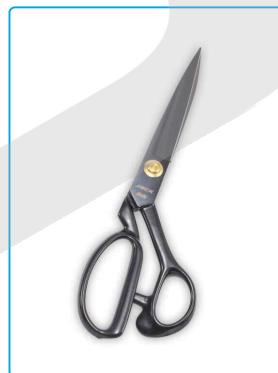

名称: **服装剪11寸**  
Description: Fabric Scissors 11"  
代码/Part NO: 810733



名称: **服装剪12寸**  
Description: Fabric Scissors 12"  
代码/Part NO: 810734

## 强力剪

Hardness Scissor



## 强力剪切 硬度性强 格外坚韧

Strong shear, Strong hardness



名称: **强力剪**  
Description: Hardness Scissors  
代码/Part NO: 810739

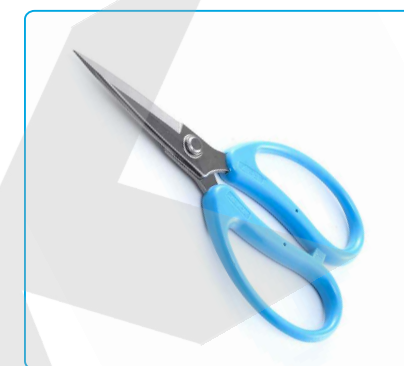

名称: **工具剪**  
Description: Scissors  
代码/Part NO: 811416

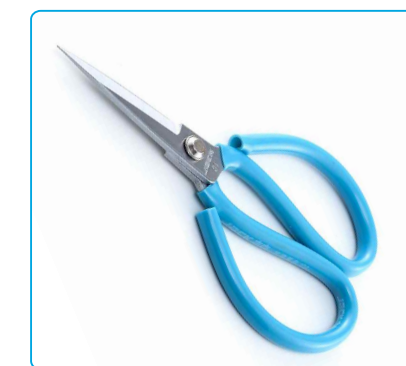

名称: **套管剪**  
Description: Scissors  
代码/Part NO: 811913

## 镊子

Tweezer



## 防滑齿设计 美观大方 圆点定位

Anti-skid design, Origin positioning



名称: **镊子-6**  
Description: Tweezer (Curve)  
代码/Part NO: 810742



名称: **防静电镊子直头**  
Description: Anti-Static Tweezer (Straight)  
代码/Part NO: 811069



名称: **防静电镊子弯头**  
Description: Anti-Static Tweezer (Curve)  
代码/Part NO: 811070



**自动卡位 一键回收 公制英尺 便于携带**  
Automatic positioning, one-key recover, metric and feet measure, easy to carry

- 轻拉皮尺即可，停手就能自动卡位
- 双面刻度印刷  
Pull the tapeline, it can automatically positioning when stop.  
Double-side scale printed.



**皮尺/卷尺** Tapeline



名称: **小号卷尺**  
Description: Tapeline S  
代码/Part NO: 810746



名称: **中号卷尺**  
Description: Tapeline M  
代码/Part NO: 810745



名称: **大号卷尺**  
Description: Tapeline L  
代码/Part NO: 810744



名称: **15GL皮尺**  
Description: Tapeline 15GL  
代码/Part NO: 810747

**裁剪小套装**

Tailor's Tool set

**小设计，大用途**  
Mini is Max



名称: **裁剪小套装**

Description: Tailor's Tool Set  
代码/Part NO: 811597

**螺丝刀**

Screwdriver



**欧洲进口榉木手柄 触摸开关 防止生锈**

The handle made of high quality beech, Touch switch, Antioxidant to prevent rusting

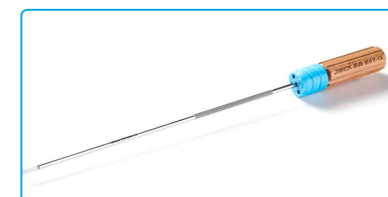

名称: **LED灯螺丝刀/12寸/直径5**  
Description: LED Screwdriver /12"/5mm  
代码/Part NO: 811730



名称: **LED灯螺丝刀/12寸/直径6**  
Description: LED Screwdriver /12"/6mm  
代码/Part NO: 811731



名称: **LED灯螺丝刀/10寸/直径6**  
Description: LED Screwdriver /10"/6mm  
代码/Part NO: 811765

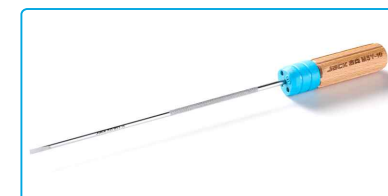

名称: **LED灯螺丝刀/10寸/直径5**  
Description: LED Screwdriver /10"/5mm  
代码/Part NO: 811766



名称: **LED灯螺丝刀/8寸/直径6**  
Description: LED Screwdriver /8"/6mm  
代码/Part NO: 811767



名称: **LED灯螺丝刀/8寸/直径5**  
Description: LED Screwdriver /8"/5mm  
代码/Part NO: 811768



## 衣车斗

Clothing Basket



名称: 活动衣车灯架  
Description: Clothing Basket with LED lamp  
代码/Part NO: 811837



名称: 活动车斗不含灯  
Description: Clothing Basket (without LED lamp)  
代码/Part NO: 811838

## 衣车灯

Sewing Lamp & Fan



名称: 无极调光磁铁灯  
(圆底座USB款)  
Description: Stepless-dimming Magnet Lamp  
(USB plug with round base)  
代码/Part NO: 811870



名称: 无极调光磁铁灯  
(圆底座2插款)  
Description: Stepless-dimming Magnet Lamp  
(plug type round base)  
代码/Part NO: 811869



名称: 无极调光磁铁灯  
(方底座2插款)  
Description: Stepless-dimming Magnet Lamp  
(plug type round base)  
代码/Part NO: 811871



名称: 无极调光磁铁灯  
(方底座USB款)  
Description: Stepless-dimming Magnet Lamp  
(USB plug with round base)  
代码/Part NO: 811872

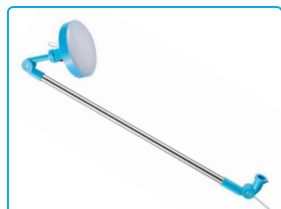

名称: 万能衣车灯  
Description: Round Lamp  
代码/Part NO: 811839



名称: 线架灯  
Description: Lamp  
代码/Part NO: 804879



名称: 旋转调光灯  
Description: Lamp  
代码/Part NO: 811947



名称: 缝纫机风扇  
Description: Fan  
代码/Part NO: 809430

# 下单系统

— Online Parts Ordering System —

零件好, 才是真的好

选零件

就选杰克原装零件

Jack original parts, Your first choice



零件服务 Spare parts service

服务承诺 We promise

结构类专用件享受1年保修；电控类享受3年保修；确保产品停产后5年内零配件供应及替换。  
1 year warranty period for mechanism parts; 3 years warranty period for control system parts;

我们为您提供 The service we provide

- 原厂零配件订单服务 Original spare parts sales
- 备用零件服务 Service spare parts

零件订单服务 Spare parts order

人工下单流程 Place order offline

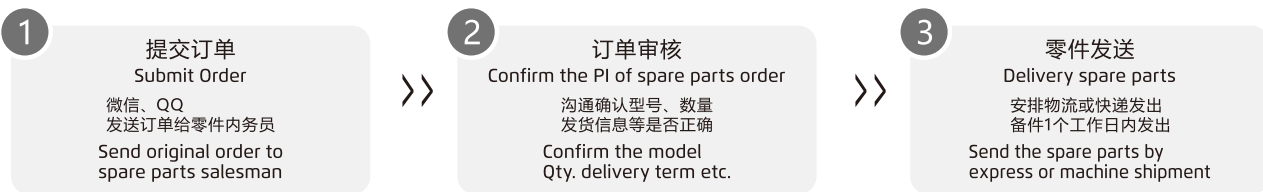

电子下单流程 Place Order online

\*正常订单：收到订单后将在半小时内审核完毕。 \*特殊有异议的订单：将转人工确认1小时内审核完毕。



便捷付款



微信扫码支付



银行转账支付



支付宝转账支付

转账帐号  
户名：中国银行台州市分行  
账号：358458335008  
开户行：中国银行台州市分行

温馨提醒：微信支付无法提供发票



为保障产品最佳缝制性能，提升产品稳定性；我们强烈建议您使用原厂原装配件。



**服务热线**  
Service Hotline

热线一：0576-89086221    热线二：0576-89086222  
 热线三：0576-89086223    热线四：0576-89086224  
 Oversea Spare Parts Department Email: [part@chinajack.com](mailto:part@chinajack.com)

**零件下单系统网址：**  
Ordering System Website Address

服务器地址 Server Address	服务器域名 Server Website	覆盖范围 Coverage
中国 China	<a href="http://shop.chinajack.com/">http://shop.chinajack.com/</a>	中国 China
中国香港 Hong Kong	<a href="http://hongkong.chinajack.com.cn">hongkong.chinajack.com.cn</a>	东南亚, 南亚, 中亚 Southeast Asia, South Asia, Central Asia
弗吉尼亚 Virginia	<a href="http://america.chinajack.com.cn">america.chinajack.com.cn</a>	美洲 America
法兰克福 Frankfurt	<a href="http://europe.chinajack.com.cn">europe.chinajack.com.cn</a>	欧洲, 中东, 北非 Europe, Middle East, North Africa
孟买 Mumbai	<a href="http://bombay.chinajack.com.cn">bombay.chinajack.com.cn</a>	南亚, 中东 South Asia, Middle East
迪拜 Dubai	<a href="http://dubai.chinajack.com.cn">dubai.chinajack.com.cn</a>	中东, 非洲, 中亚 Middle East, Africa, Central Asia